

Ci/SfB
UDC 628.24

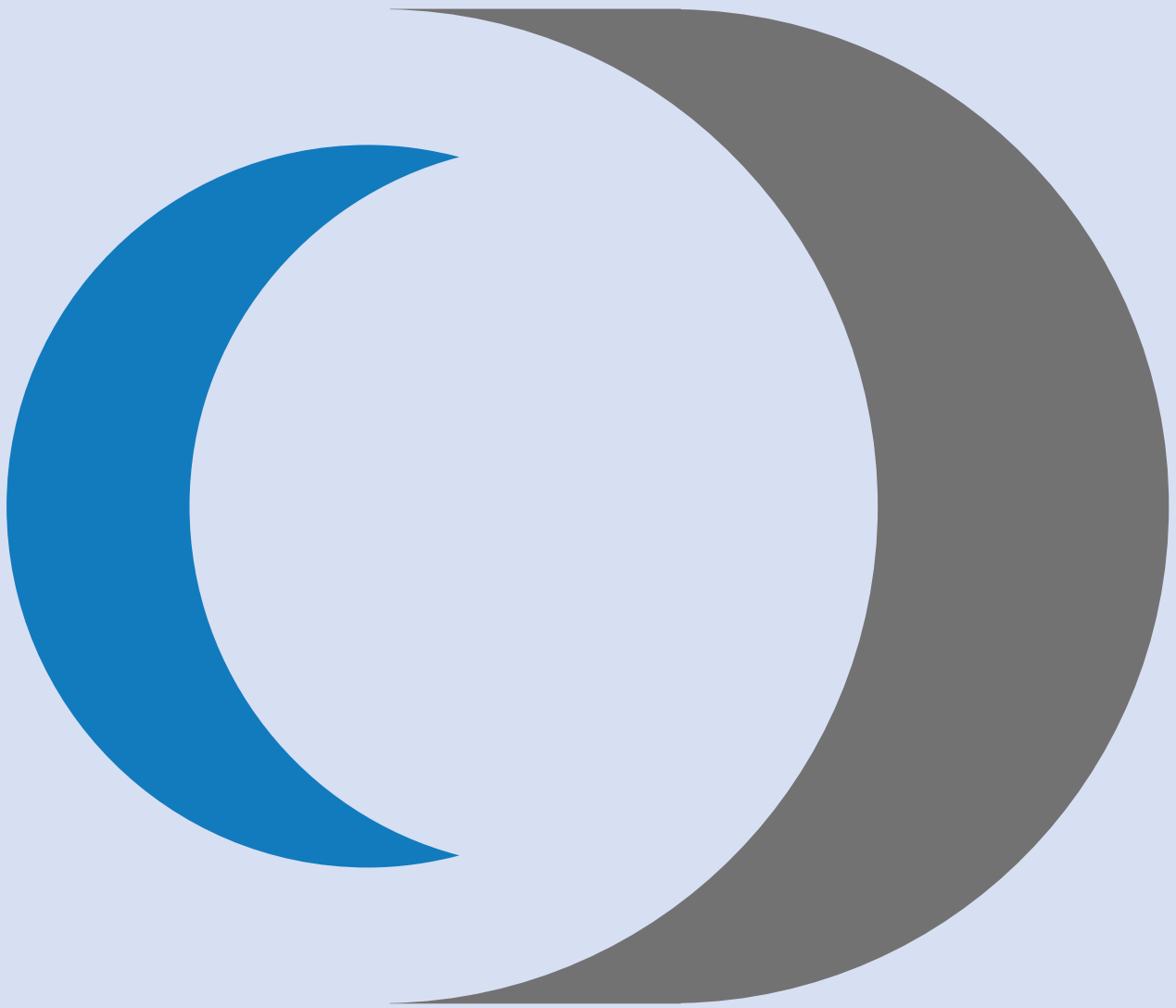

THE COMPLETE TECHNICAL DESIGN GUIDE



Sir Joseph Bazalgette (1819 – 1891) As Chief Engineer of London's Metropolitan Board of Works his major achievement was the creation of a sewer network for central London. Completed in 1858, it extended 82 miles, required 670,000m³ of concrete and is still in use today.

'Sewerage' is the entire system of pipes, manholes, gullies and channels.

'Sewage' is the foul water effluent that flows within a sewerage system.

A 'Sewer' is the pipeline, either for foul or for surface water.

FOREWORD

Precast concrete pipeline systems are the UK's choice for drainage and sewer solutions. With the inherent benefits of concrete in terms of cost, strength, inertia and durability, precast systems are the preferred choice with a design life in excess of 100 years.

Concrete drainage units manufactured in accordance with BS EN 1916 and BS EN 1917 are suitable for slightly aggressive chemical ground conditions. In the UK, some soils are more aggressive in nature. As a safeguard, the provision of a concrete suitable for ACEC AC-4 conditions as described in Building Research Establishment Special Digest 1 2005 is specified. The preferred method to achieve AC-4 for a 100 year intended working life is the use of a DC-4 concrete with surface carbonation (i.e. precast concrete) without the need for additional protective measures.

DC-4 concrete is adequate for the vast majority of discharges in normal conditions of use. However, further consideration should be given to suitable additional protective measures in the following cases:-

- **where a sewer, drain or other component within the system is liable to carry untreated or corrosive trade effluents**
- **a rising main discharge**
- **septic sewage**
- **inadequate ventilation.**
- **pipeline systems exposed to the highest level of aggressive conditions (AC-5 family).**

In general, the type of surface protection will be specified by the construction designer and will be provided by the site contractor rather than the manufacturer of the pipeline system. Appropriate options are discussed in Section D6.4 of Special Digest 1, Concrete in Aggressive Ground.



CONTENTS

1: SYSTEM DESIGN	06
1.1 Pipeline Hydraulic Design	06
1.2 Pipeline Structural Design	19
1.3 Manhole Design	32
1.4 Box Culvert Design	39
2: INSTALLATION- PIPES	49
2.1 Planning	49
2.2 Handling and Storage	49
2.3 Excavation and Laying	52
2.4 Jointing	54
2.5 Reinstatement	56
2.6 Testing	56
2.7 Jetting	58
3: INSTALLATION – JACKING PIPES	59
3.1 Introduction	59
3.2 Technique and Equipment	59
3.3 Advantages	59
3.4 Products	60
3.5 Further Information	60
4: INSTALLATION - MANHOLES	61
4.1 Planning	61
4.2 Handling and Storage	61
4.3 Construction	61
4.4 Jointing	62
4.5 Reinstatement	63
4.6 Testing	63
5: INSTALLATION - BOX CULVERTS	64
5.1 Planning	64
5.2 Delivery, handling and storage	65
5.3 Construction	66
5.4 References	67
6: REFERENCES AND FURTHER READING	68

1: SYSTEM DESIGN

1.1 PIPELINE HYDRAULIC DESIGN

1.1.1 Pipeline Design

Background

There are two main categories of drainage:

1. **Surface (or Storm) water systems** which generally discharge untreated into rivers or water courses. Surface water includes agricultural, roof or paved areas and highway drainage.
2. **Foul water systems** that feed into sewage treatment plants. Foul water can be from either domestic or industrial sources.

Up to the early 20th century, the majority of drainage systems were 'combined', that is, the foul and surface water fed into the same main sewer. More recent installations opted for separate systems. To further complicate the situation there are partially separate systems where in times of surface water flooding, provision is made for cross-linking of the two systems. Combined systems are still sometimes used, although the government is insisting that they are phased out and replaced by separate systems.

Even today, for some new installations, mis-connections between surface water and foul water systems are a problem. The design of drainage should be integral to the design of a development and follow an holistic approach, working from the whole to the part and not the other way round.

General

The capacity of sewers are selected to meet the design criteria for the hydraulic and environmental performance of the system. Pipes must be selected to:-

- transport the required design flows
- limit sediment build up
- reduce risk of blockage
- allow effective maintenance

Design considerations

In the design of a surface water or foul water sewer, similar criteria must be considered:-

- average and peak flows and their duration gradient
- the position of the sewer within the network and whether flooding can be tolerated
- the cover depth of the sewer
- any topographical or structural feature (such as a valley, building or embankment)
- surface characteristics (road, field or paved area)
- access to the sewer for maintenance (frequency, size, spacing and depth of manholes)

The basis for design is that flows in sewers are turbulent. Two formulae are recommended for calculating turbulent flows in sewers: Manning and Colebrook-White.

Pipe headlosses

When using recommended hydraulic pipeline roughness values, it is necessary to establish whether allowance has been made for local headlosses. The hydraulic pipeline roughness (K_s) or the Manning flow coefficient (K) should allow for headlosses due to pipe material, taking into account other factors including the internal profile of the pipe in its in-service state and biofilms that grow on the pipe surface below water level. The effect of the biofilm can be more significant than any difference in the roughness of the material without the biofilm. A single value regardless of pipe material is therefore often used.

The Manning formula

For both circular and non-circular cross-sections whether running full or partially full, the velocity of flow is given by the formula

$$V = KRh^{2/3} i^{1/2}$$

Where:

V = mean fluid velocity (m/s)

K = Manning flow coefficient

Rh = hydraulic radius

i = bed slope

= A/P

= $\frac{\text{flow cross sectional area}}{\text{wetted perimeter}}$

The Colebrook-White formula

The general formula for flow in a circular pipe is:

$$\frac{1}{\sqrt{\lambda}} = -2 \log_{10} \left(\frac{Ks + 2.51}{3.71 Re \sqrt{\lambda}} \right)$$

Where:

λ = Darcy friction coefficient, $64/Re$

Ks = a linear measure of effective roughness (m)

Re = Reynolds number, $\frac{V D}{\nu}$ where V = mean fluid velocity (m/s)

D = hydraulic diameter of pipe (m)

ν = Kinematic viscosity ($1.31 \times 10^{-6} \text{m}^2/\text{sec}$) = μ/ρ (m/s) where

μ = dynamic viscosity (Ns/m² or kg/ms)

ρ = density of the fluid (kg/m³)

In engineering terms, the expression for transitional pipe flow may be written:

$$V = -2 \sqrt{(2gDi)} \log_{10} \left(\frac{Ks + 2.51 \nu}{3.71 D \sqrt{(2gDi)}} \right)$$

g = gravitational acceleration (9.81 m/sec²)

i = hydraulic gradient; invert and water surface slope in uniform flow in open channel.

The depth of flow in the sewer will affect the hydraulic efficiency and Chart A1 gives the proportional velocity and discharge in part-full circular sections.

For design purposes, 'Sewers for Adoption' recommends Ks values of 0.6mm for surface (storm) water and 1.5mm for foul water sewers irrespective of pipe material. The charts (A2 and A3) relate to these values.

For the full range of Ks values see

- Tables for the Hydraulic Design of Pipes, Sewers and Channels (8th edition). HR Wallingford, DIH Barr, 2006, Thomas Telford
- Charts for the hydraulic design of channels and pipes. Hydraulics Research Station Sixth Edition 1990.

For further detailed information on system design see European Standard EN 16933-2 which supersedes EN 752 on aspects of hydraulic design for drains and sewer systems.

This section is generally based on the guidance and recommendations within Sewers for Adoption and BS EN16933-2:2017 Drain and sewer systems outside buildings. Design. Hydraulic design.

1.1.2 Hydraulic design of surface water sewers

Surface water runoff from impermeable surfaces, such as roads and car parks must first pass through an interface between the impermeable surface and the drain or sewer system. To minimise the impact of sewer flooding, the flow at this interface must be considered and its capacity to accommodate the flow passing through it.

For smaller schemes, a simple approach is recommended where sewers are usually designed to run full, without surcharge, for relatively frequent design rainfall events on the basis that this will generally provide protection against sewer flooding from more severe rainfall events. Rainfall intensity and duration figures applicable to the area should be used.

For larger schemes, where damage or public health risks are significant, the level of sewer flooding protection should be directly assessed. A sewer flow simulation model based on the Wallingford Procedure should be used to check the level of flood protection against the sewer flooding design criteria and the design adjusted where the required sewer flooding protection is not achieved.

Where storage is provided to control surface water discharges, the designer should demonstrate that:

- the system upstream, including inlets, has sufficient capacity to accommodate the flows to storage
- an overland flood exceedance route is provided that will deliver sufficient capacity

Large (“oversized”) pipes may be used as part of a Sustainable urban Drainage System (SuDS) - see section 1.1.6. In these situations the pipe is sized to accommodate a calculated volume of surface water to store and attenuate flow at the discharge point. For “on-line” attenuation systems a low-flow channel is usually provided within the invert to encourage self-cleansing. If oversized pipes are used off-line from the sewer, self-cleansing velocities are not expected and effective silt removal must be provided upstream of the storage.

1.1.3 Hydraulic design of foul water sewers

For drains and sewers serving small populations, the capacity of the pipe is often established by the minimum pipe size specified by the relevant authority.

In gravity drains and sewers, the ratio between the peak flow and the average dry weather flow reduces as the flow moves downstream.

The peak design flow rate for dwellings may be based on:

- BS EN16933-2:2017 and calculated in accordance with BS EN12056-2:2000 Gravity drainage systems inside buildings Part 2: Sanitary pipework, layout and calculation - System II.

Or

- 4000 litres per dwelling per day (0.05 litres per second per dwelling). This is not a daily average water usage and represents the peak flow rate from a number of appliances. Reducing daily water usage does not necessarily reduce the peak flow rate.

Unless specifically directed by the client, the choice of method is at the discretion of the designer.

For self-cleansing properties, the foul sewer must flow at a minimum of 0.75 m/sec at one third of the design flow, the main governing factors being the pipe diameter, the gradient and the volume of effluent (the larger the pipe and the flatter the gradient, the greater amount of effluent will be required to achieve self-cleansing velocity).

If there is only a small flow, it is unwise to select too large a pipe “to allow for possible development” as this may lead to settling out of solids, long retention periods, blockages and build-up of septicity. A limited period of surcharge and backing up of a sewer is generally preferable to a consistently low velocity and its attendant problems.

It should be noted that the following hydraulic design charts are for reference only to help demonstrate a basic hydraulic design process. Users should acquire the full HR Wallingford publication if they wish to carry out their own design projects. Pipe networks, with interconnecting branches, manholes and changes in pipe size, direction and gradients are far more complex design challenges and would normally require computer modeling software.

Chart A1. Relative Velocity and Discharge in a Circular Pipe for any Depth of Flow.

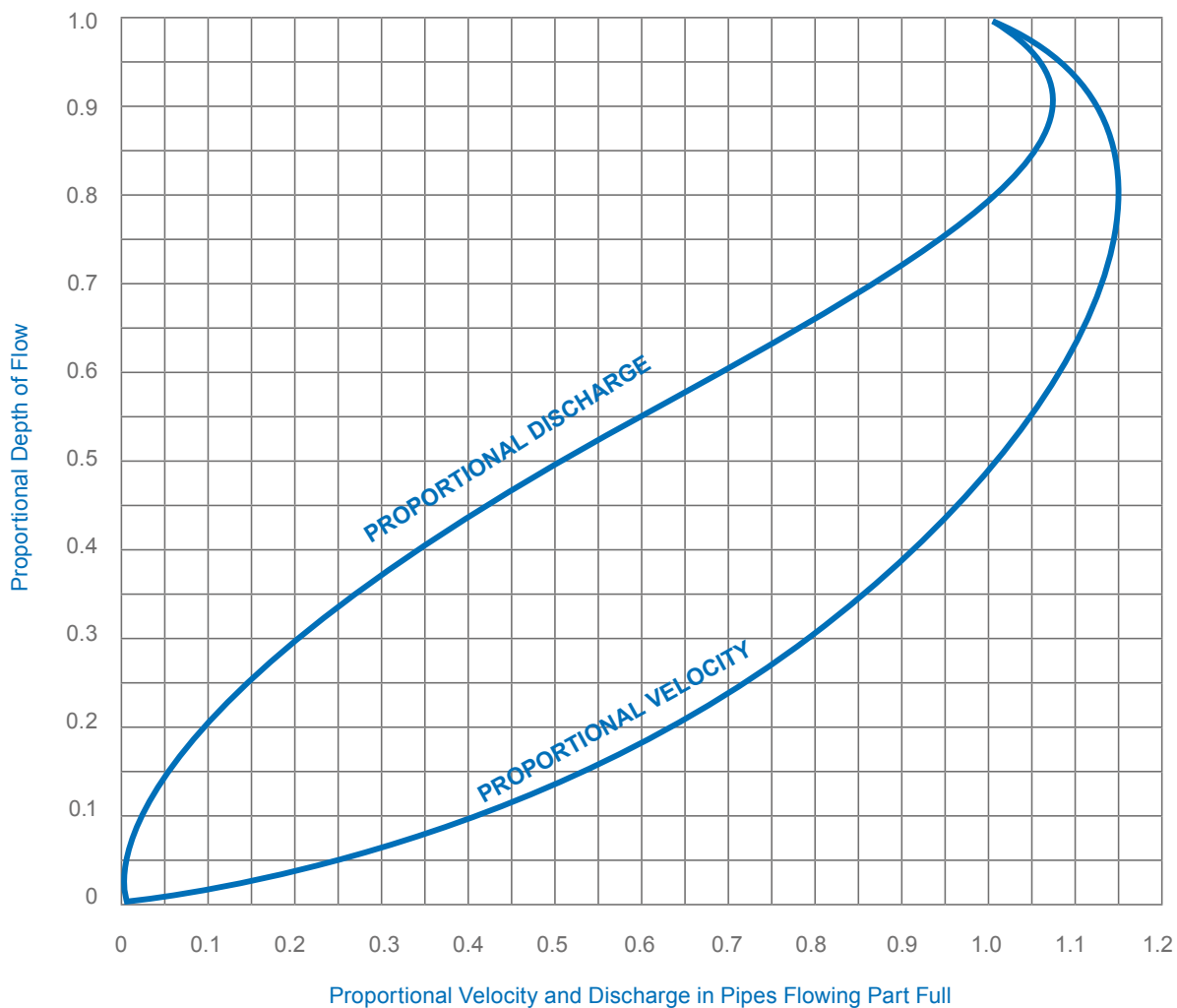

1.1.4 Hydraulic Flow Charts

Chart A2

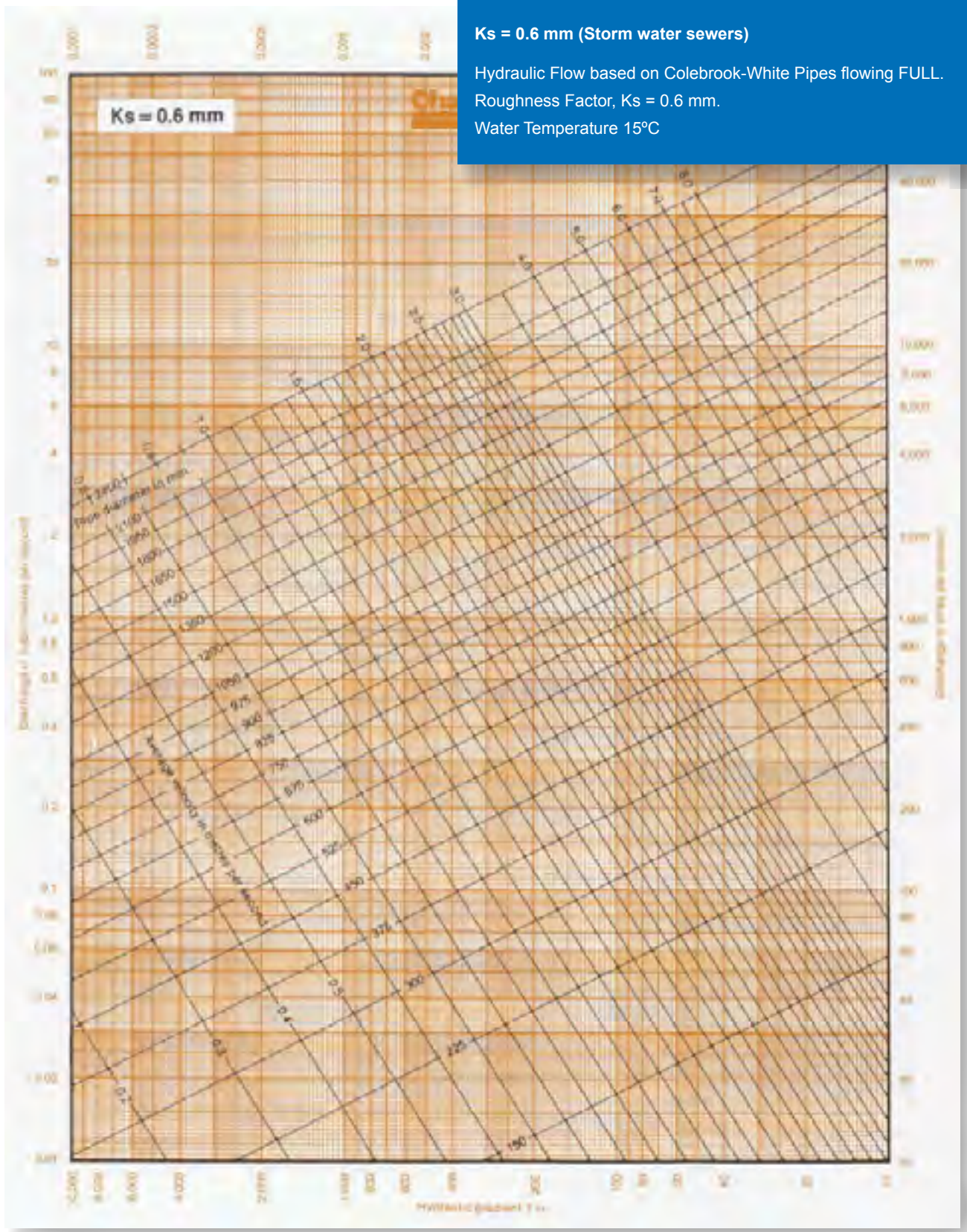
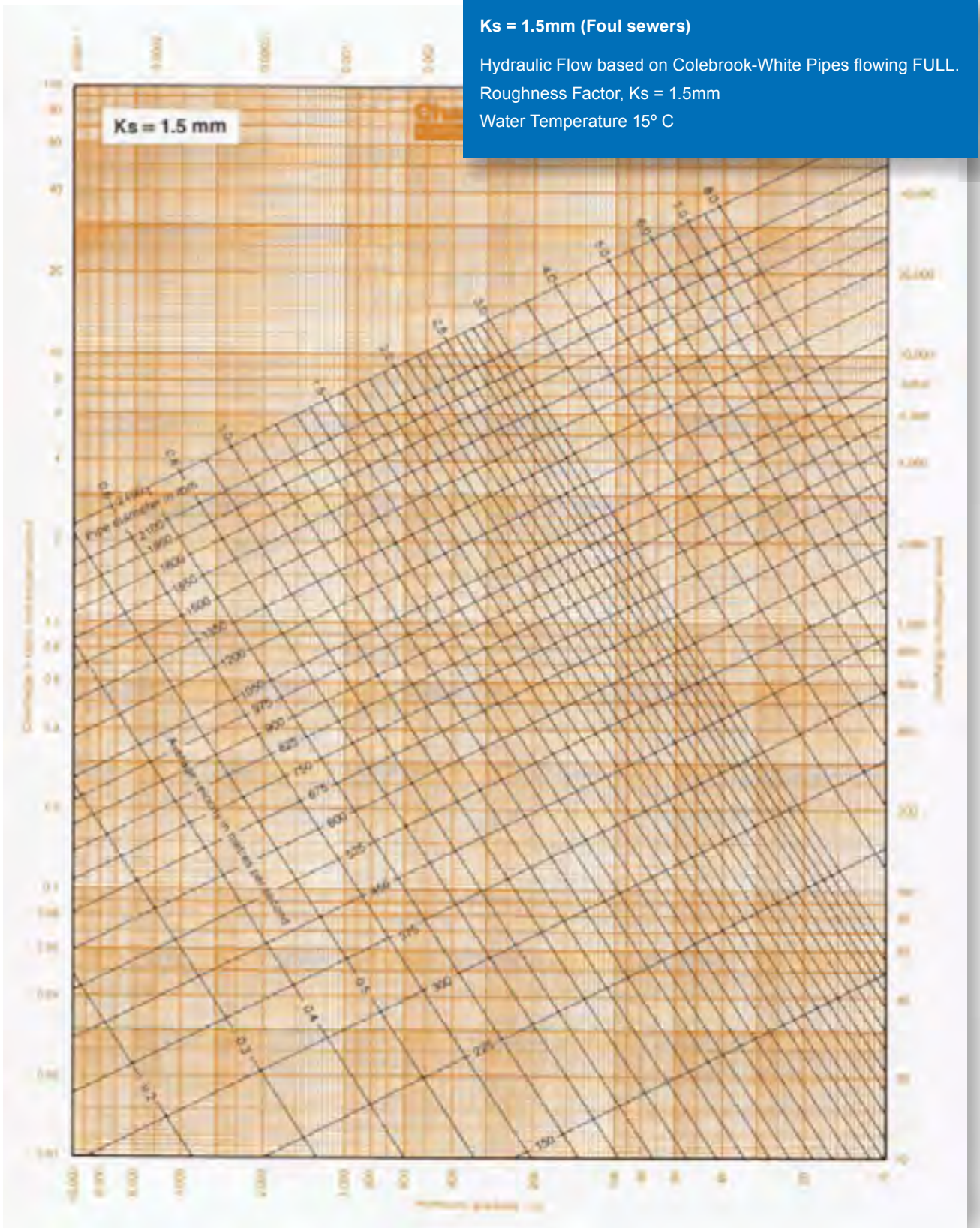

Chart A3



1.1.5 Worked examples

1) Design of surface (storm) water sewer

Total length of pipeline = 2300m. Total fall to outlet = 15m. Design discharge = 0.3m³/s

Determine required pipe size for: a) Pipe flowing full b) Pipe flowing quarter full

Ks for storm water sewer = 0.6mm
 Hydraulic gradient = $\delta y / \delta x$
 = 15m / 2300m
 = 0.0065
 = 1:153

Example 1a) Pipe flowing full

Step 1: read off discharge = 0.3m³/sec on y-axis and project a line horizontally across the chart

Step 2: read off hydraulic gradient = 1:153 on x-axis and project a line vertically across the chart

Step 3: at intersection of Steps 1 and 2 project a line parallel to sloping line for pipe (internal/nominal) diameter lines.

The required pipe size is between DN450 and DN525. DN450 is insufficient capacity so select DN525.

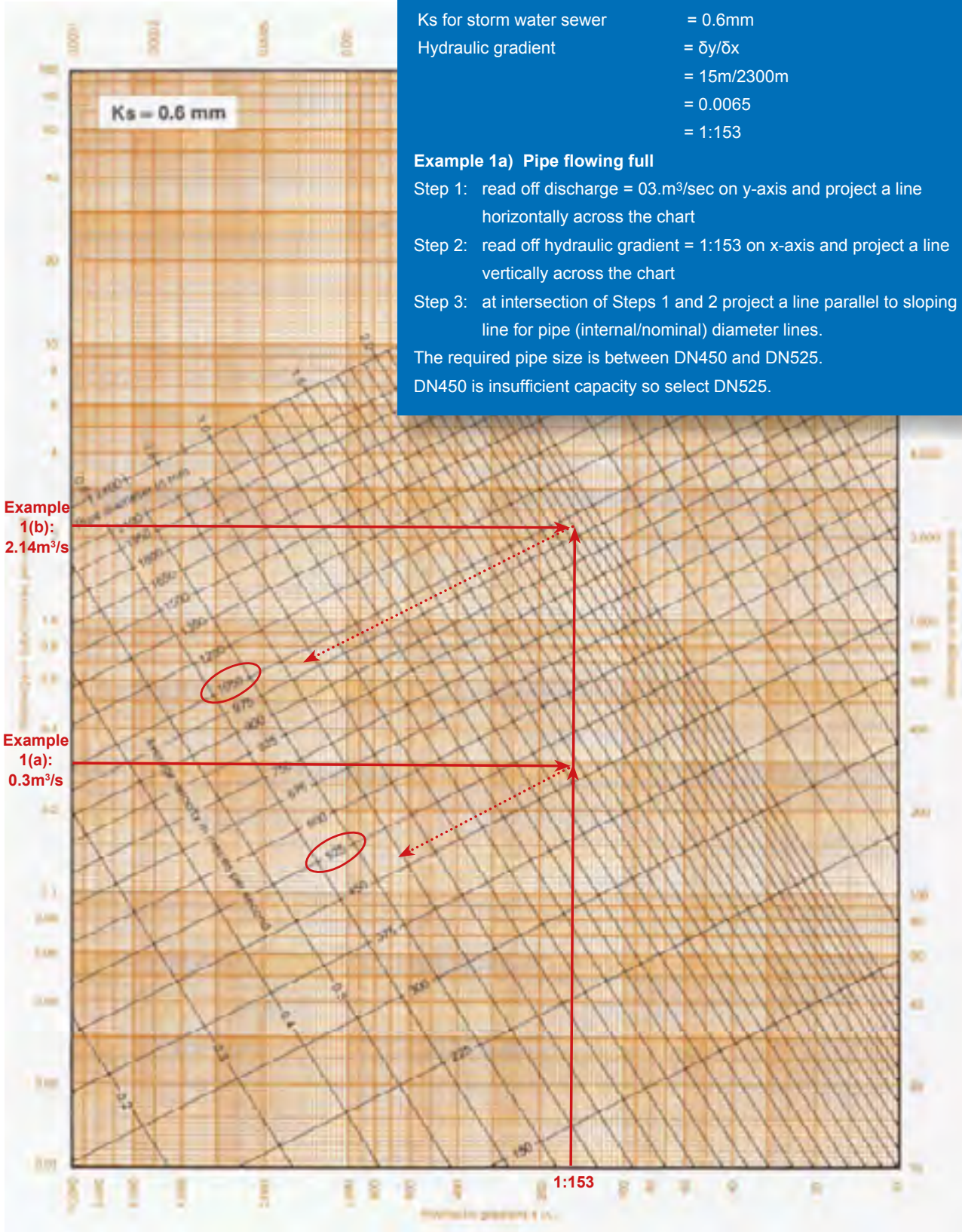

Example 1(b): 2.14m³/s

Example 1(a): 0.3m³/s

1:153

(a) PIPE FLOWING QUARTER FULL:

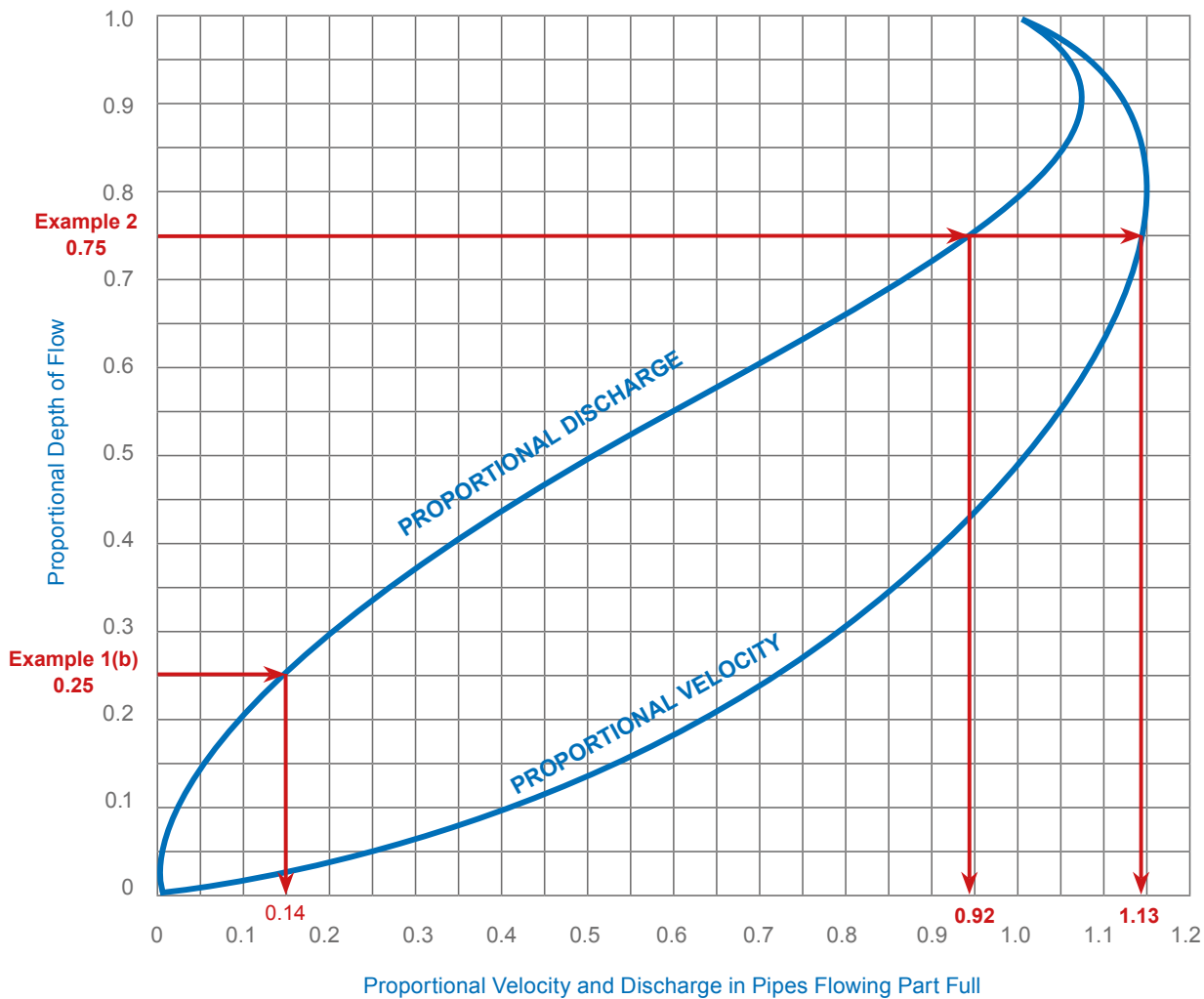
**Example 1b) Pipe flowing quarter full**

Step 1: read off 0.25 (a quarter) on the proportional depth of flow y-axis and project a

line horizontally to intersect with the proportional discharge curve

Step 2: at the intersection of Step 1, project a line vertically down to the x-axis

Step 3: read off proportional discharge = 0.14

Step 4: equivalent full pipe flow is $0.3\text{m}^3/\text{sec} / 0.14 = 2.14\text{m}^3/\text{sec}$

Step 5: from the chart on page 10, project a line horizontally from discharge = $2.14\text{m}^3/\text{sec}$ on y-axis

Step 6: project a line vertically from hydraulic gradient = 1:153 to intersect with Step 5

Step 7: project line parallel to sloping line for pipe (internal/nominal) diameter lines.

The required pipe size is between DN975 and DN1050. DN975 is insufficient capacity so select DN1050

2) Design of foul water sewer

Housing Scheme =180 houses. Total length of pipeline =1650 m. Total fall = 3.6m

Sewers for Adoption - 4 m³/ dwelling / day. Assume half flow over 6 hours and 6 x average flow as design maximum.

$$= \frac{1}{2} \left(\frac{4(\text{m}^3 / \text{dwelling/day}) \times 180 \text{ dwellings}}{6 (\text{hours}) \times 60 \times 60} \right) \times 6 (\text{av.Flow}) = 0.1\text{m}^3/\text{sec}$$

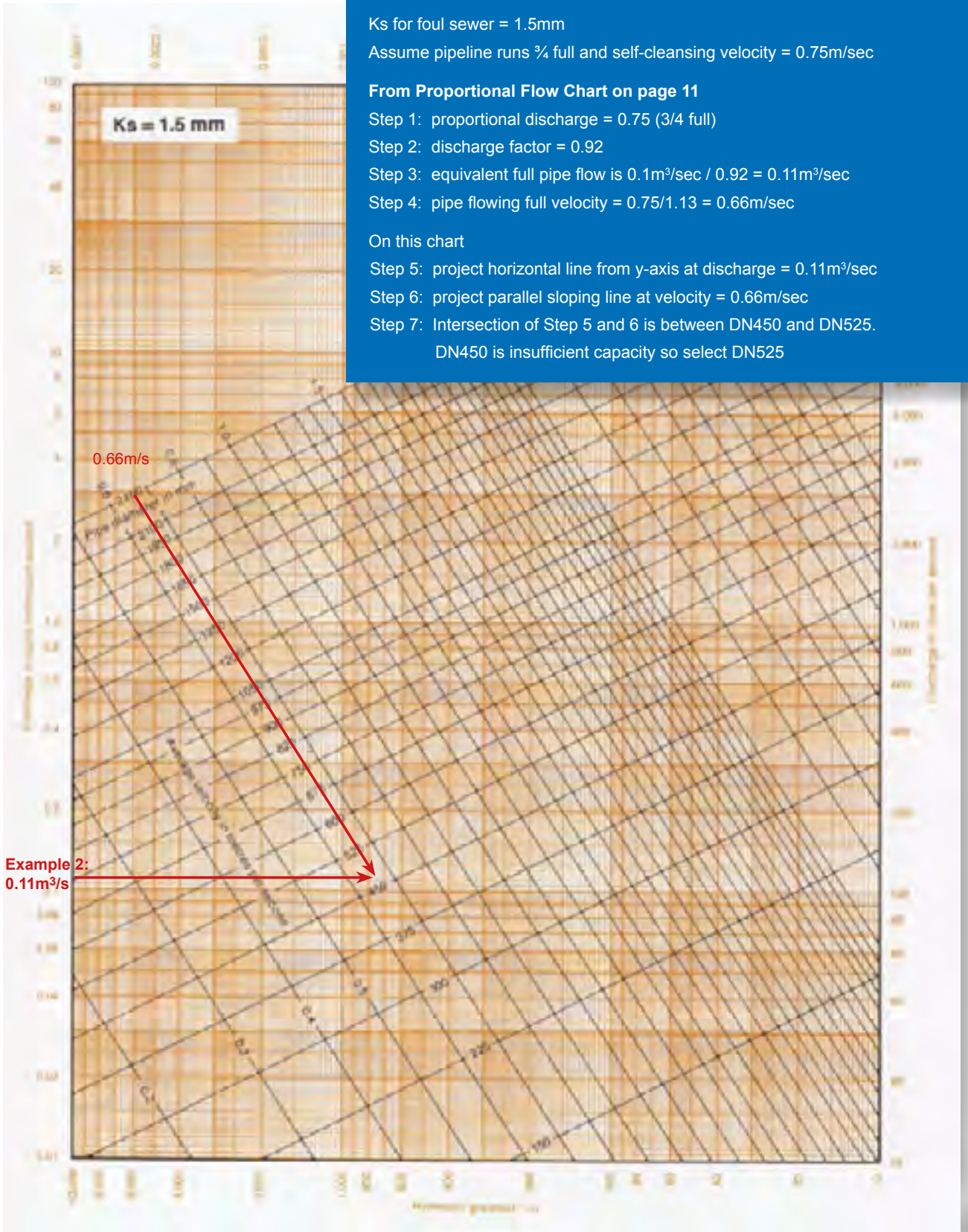

1.1.6 Sustainable Urban Drainage Systems (SuDS)

BPDA Proprietary Sustainable Drainage Systems and Components

The use of sustainable drainage systems, known as **SuDS**, and best management practices should be an integral part of any development's surface water management strategy. This should provide a basis for replicating the response of a catchment and its surfaces by mimicking, to some extent, the behaviour of surface water on the developed site as if it had remained undeveloped. Modern sustainable drainage systems should aim to offer improvements to existing surface water runoff, negating any increased risk of flooding by using methods for managing surface water by focusing on three key elements:

- Controlling surface water quantity (reducing off-site low rates)
- Improving surface water quality
- Providing added amenity value to the development

The successful implementation of a sustainable drainage scheme should consider a combination of natural and proprietary techniques, complemented by traditional drainage methods, where appropriate.

It is essential that planners, designers, installers and operators of SuDS systems take into account the importance of whole life maintenance and the use of suitable components that deliver authentic sustainable drainage performance and longevity.

Management Train

The SuDS philosophy is underpinned by the water "Management Train".

The Management Train applies SuDS techniques in series and is based on:

- Prevention; good housekeeping measures within the development
- Source control; runoff managed as close as possible to where it originates as rain
- Sub-catchments; division into small areas with different drainage characteristics and land use
 - Site Control; dealing with runoff within or local to the development
 - Regional Control; e.g. SuDS features within amenity space before final outfall









The Management Train can be divided into the following processes:









- | | | |
|----------------|---------------|--------------|
| • Collection | • Treatment | • Re-use |
| • Infiltration | • Attenuation | • Conveyance |

BDPA Sustainable Drainage Solutions

BDPA members offer a wide variety of proprietary SuDS components and systems suitable for use within a sustainable drainage system.

These are listed in the following table indicating their functions within the Management Train. For specific product information [please consult our members](#).

SuDS Component	Collect	Treat	Re-Use	Infiltrate	Attenuate	Convey	
 Circular pipe				•	•	•	Rigid pipeline system with flexible joints for conveyance of stormwater and storage / attenuation, available with optional dry weather flow channel and side entry manhole access. Perforated version enables stormwater to percolate into the ground.
 Elliptical pipe					•	•	Elliptical pipeline system for conveyance of stormwater and storage/attenuation with minimal cover requirement, available with dry weather flow channel and side or top entry manholes.
 Ovoid pipe					•	•	“Egg-shaped” pipeline system with integral dry flow channel. Higher velocity at low flow depths compared to circular pipe providing reduced risk of siltation.
 Modular Tank Systems					•		Modular tank systems using precast base, floor and roof panels
 Manhole					•	•	Off-site, watertight solution pre-benched and configured to required inlet/outlet orientation.
 Multi Purpose Chamber System					•		Precast box, base and cover slab in a range of sizes and loading categories.
 Soakaway		•		•	•		Perforated chamber which may be open void (providing storage) or contain filter medium (providing treatment) to facilitate percolation of stormwater into the ground.
 Flow Control Chamber					•	•	Off-site solution with pre-installed flow control device such as penstock, non-return valve, weir wall, orifice plate, vortex flow regulator.
 Road Gully	•	•			•	•	Designed to receive storm water runoff from paved surfaces and first-line gravity separation of silt.

SuDS Component		Collect	Treat	Re-Use	Infiltrate	Attenuate	Convey	
	High Capacity Road Gully	•	•			•	•	Enhanced capacity road gully for first line separation of silt and surface water runoff from surfaces prone to flooding.
	Filter Gully	•	•					Gully pre-fitted with filter for removal of oils and silt.
	Hydro-dynamic Vortex Separator		•			•	•	Chamber for silt capture, litter and some oils.
	Treatment Chamber		•			•	•	A variety of pre-configured chambers for removal of foreign objects and pollutants such as litter, oil, grease, silt & heavy metals.
	Catch Pit		•			•	•	For the gravity separation of debris and silt to prevent it passing downstream.
	Filter catch Pit		•			•	•	Catch pit pre-fitted with filter for removal of oils and silt
	Headwall						•	Inlets and outlets, available with flap valves and grills, connecting swales, ponds, detention basins, etc. to underground pipes.
	Cascade Unit						•	To protect embankments from erosion.
	High Capacity Slot Drain	•					•	Integrated gasket joint and excellent flow characteristics for surface runoff and below ground applications.

SuDS Component	Collect	Treat	Re-Use	Infiltrate	Attenuate	Convey	
 Perforated Drainage Trough					•	•	For shallow and deep channel applications.
 Box Culvert					•	•	Range of sizes. Available with optional dry weather flow channel.
 Rainwater Harvesting Tank			•		•		Domestic and commercial rainwater harvesting systems
 Rainwater Filter Chamber		•	•		•		Rainwater harvesting pre-tank for leaf and grit removal.
 Grey Water Recycling Tank		•	•				Domestic and commercial grey water recycling systems

SuDS References

Information sources to help plan, design and implement sustainable drainage:

1. The community for sustainable drainage. www.susdrain.org
2. CIRIA. The SuDS Manual C753. www.ciria.org
3. Association of SuDS Authorities (ASA). Guidance on SuDS standards: <https://www.suds-authority.org.uk/wp-content/uploads/2018/12/non-statutory-technical-standards-guidance.pdf>
4. CIRIA. Site Handbook for the Construction of SuDS C698. www.ciria.org
5. BS 8582:2013 Code of practice for surface water management for development sites.
6. CIRIA. Designing for Exceedance in Urban Drainage Good Practice C635. www.ciria.org
7. CIRIA. Sustainable Drainage Systems. Hydraulic, Structural and Water Quality Advice C609. www.ciria.org
8. CIRIA. Infiltration Drainage – Manual of Good Practice R156. www.ciria.org
9. CIRIA. Control of Pollution from Highway Drainage Discharge R142. www.ciria.org
10. British Hydrological Society. Sources of Hydrological Data. http://www.hydrology.org.uk/Data_sources.php
11. WRc. Sewers for Adoption. www.wrcplc.co.uk
12. Local Government Association. Flownet Knowledge Hub. A group for all those interested or involved in flood risk and water management. <https://knowledgehub.local.gov.uk/group/flownet>
13. National Standards for sustainable drainage systems. Designing, constructing, operating and maintaining drainage for surface runoff. www.defra.gov.uk
14. For information on SuDS legislation, questions on government policy and to register to receive updates. email suds@defra.gsi.gov.uk

1.2 PIPELINE STRUCTURAL DESIGN

1.2.1 Design Principles

The forces acting on a cross section of pipeline arise from three main sources:

- A) Weight of overlying fill, including any local surcharge.
- B) Soil pressures transmitted to the pipe from surface loads, i.e. traffic and other transient loads.
- C) Supporting reaction below the pipe.

The weight of water within the pipe is only significant for larger diameter pipes.

A: Weight of overlying fill

There are four main conditions in which pipes are installed:

- a) "Narrow" trench.
- b) "Wide" trench, or on the surface of ground over which an embankment is then built (positive projection condition).
- c) Narrow trench over which an embankment is then built (negative projection condition).
- d) Tunnel, heading or by jacking.

The load W_c imposed by the backfill on a pipe in a "narrow" trench can be found from Marston's formula from which the Tables have been compiled in Section 1.2.5.

These Tables are only applicable to rigid pipes laid in "Narrow" trench conditions.

Note: The revision of BS9295:2020 has placed more emphasis on wide trench conditions. If designers have sufficient control over the installation stage, the load-reducing effect of a narrow trench can be incorporated into the design. It is recommended a maximum trench width is stated on all designs. Narrow trench designs generally produce a more economic design and have been standard design procedure for many years without any adverse issues. In all other cases where the above cannot be complied with, the design should be based on the more conservative wide trench model.

B: Traffic and other transient loads

Measurements have shown that on large civil engineering works pipes may well be subjected to their highest loads during construction. Here, three categories of traffic loading are considered and rigid pipes should normally be designed to withstand the most onerous likely to occur.

If during construction it is clear that excessive site traffic loading will occur, the design should be checked accordingly or special crossing places must be designated.

a) Main road loading is intended to apply to all main traffic routes and to roads liable to be used for the temporary diversion of heavy traffic.

As a guide it may be assumed that such roads carry at least 200 commercial vehicles per day in each direction. The design principals given in BS 9295:2020 'Guide to the structural design of pipelines' have been assumed.

b) Field loading applies to fields, gardens and lightly trafficked access tracks. This loading is also considered to be adequate to cater for occasional heaps or stacks of materials on the ground surface. Massive heaps or stacks likely to produce a more severe loading should be treated as a special design.

In assessing the loading category, regard should be paid to the possible future upgrading of a road. Pipes under verges should normally be treated as though under the road, with the possible exception of motorways and trunk roads and should take account of any planned road

improvement. For non-public roads such as industrial estate roads or roads within works, an assessment should be made of the heaviest vehicle likely to use the road, and one of the above three loading conditions selected as appropriate.

C: Supporting reaction below the pipe

British Standards for concrete pipes give maximum crushing loads for each diameter and strength class of pipe. Loads are applied in a 3 edged loading test described in BS EN 1916 and BS 5911-1. The pipe must not collapse under the maximum load specified.

Proof test loads are also specified. Reinforced pipes must not crack by more than a specified amount under the proof load. The only proof load test for unreinforced pipes is the maximum load.

Pipes of a small diameter (Less than DN 300) may fail as a beam. BS EN 1916 and BS 5911-1 include suitable values of bending moment resistance.

Pipe bedding

This term is used to describe the complete arc of material within the trench, or in the case of Class “C” or Class “D” beddings, a special preparation of the trench bottom. For further information, see Section 1.2.4 “Pipe Bedding”.

Bedding factor

In the standard test on pipes the vertical loading and supporting reactions are line loads and any trench situation in the field is unlikely to produce such an onerous loading condition. The strength of the pipe determined in the crushing test can therefore be multiplied by a bedding factor which represents the amount by which the stresses in the pipe are reduced because of the spreading properties of the bedding for load and reaction.

The value of a bedding factor for a particular method of construction is not a precise figure but is affected by the quality of workmanship. The values given whilst being conservative assume a reasonable standard of workmanship and supervision. If the designer needs a somewhat higher bedding factor than stated a high standard of workmanship and supervision must be specified and guaranteed; alternatively a higher strength pipe may be considered where available. If a higher strength pipe is available adequate time must be allowed for the manufacturer to supply.

Factor of safety

For structural design to BS 9295:2020 unreinforced pipes should be designed with a factor of safety (Fse) of 1.25 (generally DN225–DN600 units are unreinforced but some manufacturers may have a different range of such pipes). The factor of safety increases to 1.5 for reinforced pipes. Confirmation should be obtained from the manufacturer or a conservative approach would be to use a 1.5 factor of safety.

1.2.2 Design Assumptions

Surface Conditions

The Tables in Section 1.2.5 are applicable only to a single pipeline laid in its own trench, and have been set out to give the loads on pipes under three surface conditions, Main Roads, Light Roads and Fields.

Alternatively, refer to www.precastdrainage.co.uk/calculators/structural-design where specific designs can be entered (note: for single pipe trench conditions only).

Backfill loads

The Tables are calculated using an equivalent soil density of 19.6 kN/m³ (approximately 2.0 tonnes/m³).

Traffic loads

The loads referred to in the design principles have values as follows:-

a) Main roads

The traffic surcharge pressures given in BS 9295:2020 have been used. These have been determined as the higher pressures calculated from Load Model 1 and Load Model 2 of BS EN 1991-2:2003. Wheel load dispersal with depth is also in accordance with BS EN 1991-2:2003.

b) Fields

Static wheel load of 30kN and an impact factor of 2.0, giving a Total Static wheel load of 60 kN; contact pressure 400kN/m².

Superimposed loads

These are not included in the Tables. If however such loads are encountered and are of sufficient magnitude, an allowance should be made.

Water Loads

These are included in the Tables. If the pipe is laid below the ground water table, an allowance for this load is not needed. However, as these loads are small by comparison with other loads on the pipe, it has been considered appropriate to include them only for pipes of DN 600 and over.

Frictional factor K

A value of 0.13 has been used for narrow trench conditions.

Recommended minimum cover over pipe

Cover depths less than the minimum values published in industry specifications and Standards should only be used with the appropriate authority's permission.

a) It is common practice that pipes laid under roads should have cover over the pipe of not less than 1.2m to avoid conflict with other services. This cover should be maintained for main roads, light roads (which may on occasion carry main road traffic) and for pipes laid under grass verges adjacent to a road. Where pipes have to be laid with less than 1.2m cover special consideration is needed to reduce the risk of damage. For concrete pipes, according to TRL tables, the cover depth under highways can be reduced down to a minimum depth of 0.6m when installed in conjunction with a full granular bed and surround (Bedding Class S).

b) For pipes laid in fields, a minimum cover of 0.6m should be provided. At shallower depths there is a risk of damage from agricultural operations.

Protection to shallow pipelines

Where pipes are required to be laid at cover depths less than 0.6m, the pipes should be protected as per the recommendations of BS 9295:2020 annex A, A13

The preferred method of protection is the use of a reinforced concrete slab being installed over the pipeline (see typical detail right).

Key

- | | |
|---|-------------------------|
| 1 Backfill | 5 Compressible material |
| 2 Concrete slab | 6 Pipe |
| 3 Reinforcement | 7 Granular surround |
| 4 Minimum 300 mm bearing on original ground | |

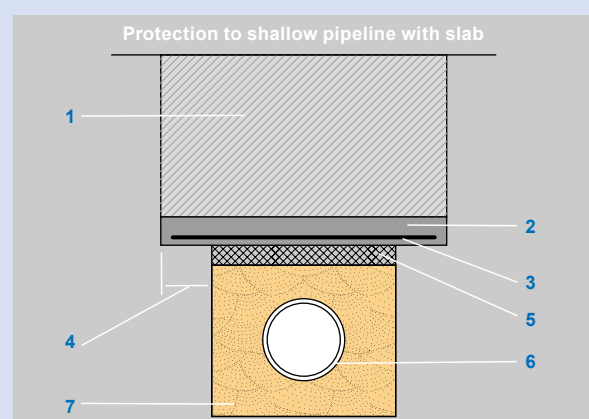

It is important that the slab extends sufficient distance beyond the trench and would depend on soil conditions (minimum bearing of 300mm each side advised). A layer of compressible material directly over the pipeline aids in the prevention of the slab loading directly onto the pipeline should settlement occur.

Another method of protection at shallow cover depth is via the use of a concrete surround. It is important in such installations to install compressible material at least every other pipe joint to ensure that the pipeline retains its flexibility.

Special consideration should be given where construction plant has to cross pipelines with shallow cover depth. Where possible, traffic should be routed over dedicated crossing points. Crossing points may consist of heavy steel plates to transfer vehicle loads or temporary additional cover emplaced over the pipeline.

Pipelines under embankments or laid in deep trenches

Where a pipeline is laid under an embankment, or where the pipeline is installed in a deep trench, it can be critical for the trench width and the distance above the crown of the pipe to be kept within the design values. Any slight increase over the designed trench width can greatly increase the pipeline's loading.

Multiple pipes in trench

For convenience, two or more pipelines may be installed in the same trench and at different levels.

Trenches can be excavated to the maximum depth to accept all pipelines, or they may be stepped in construction where levels of the pipelines are different.

Careful consideration should be undertaken to assess the loading and possible implications of installing multiple pipelines in the same trench.

The horizontal distance between adjacent pipelines will largely be dependent on the type of bedding/backfill material used to surround the pipelines. With rounded gravels it's possible to achieve minimal spacing between the pipelines (just room to provide access for the gravel to be working in and around the pipes), whereas an angular/cohesive material may require upwards of 400mm or greater (depending on pipe sizes) to enable suitable access for placement and compaction of the materials.

More advice can be found at BS 9295, A.8.

1.2.3 Design Method

The established method for calculation of loads on buried rigid pipes is given in BS 9295:2020. This provides both detailed design information and guidance. Calculation examples are provided in Annex A.26. the principles of which are explained below.

In general pipelines are laid in trenches and the pipes used are designed to carry the backfill, traffic loads and, when the diameter is 600mm or more, some part of the water load under working conditions.

In order to improve the load carrying capacity of the pipe it is laid on one of several classes of bedding (see Table A2). Each type of bedding is allocated a "bedding factor" (F_m) which may be regarded as a multiplier applied to the test load of the pipe.

The trench is excavated in the natural soil, the pipe is laid on the selected bedding and the trench backfilled. Load on the pipe due to the backfill develops as the fill material settles. The load on the pipe due to the backfill is therefore the weight of the backfill taken over the full trench width but reduced by the shear force from the trench walls acting upwards (see Fig.A1).

This state is called the **narrow trench condition**. The backfill load is calculated by using the Marston formula. Wide trench conditions should be considered if the trench width is expected to exceed the widths given in the tables.

$$W'_c = C_d w B_d^2$$

Where:

W'_c = Backfill load (kN/m)

C_d = Soil load coefficient in narrow trench conditions, dependent on soil type.

Note: This can vary dependent on soil type and ratio of cover depth to trench width, however conservative standard assumptions are generally used.

w = Soil density (kN/m³)

B_d = Width of trench (m)

Provided that the trench width does not exceed the values given in the tables, the loads given are conservative and may be used with confidence.

The trench widths given will provide adequate working space around the pipe for laying and jointing and also sufficient room to place and consolidate the bedding specified.

As indicated, the friction acting against the backfill is provided by the trench walls and is roughly constant at a particular depth. If however the trench width is increased radically, B_d^2 in the Marston formula is also increased and a reappraisal of the load on the pipe must be considered.

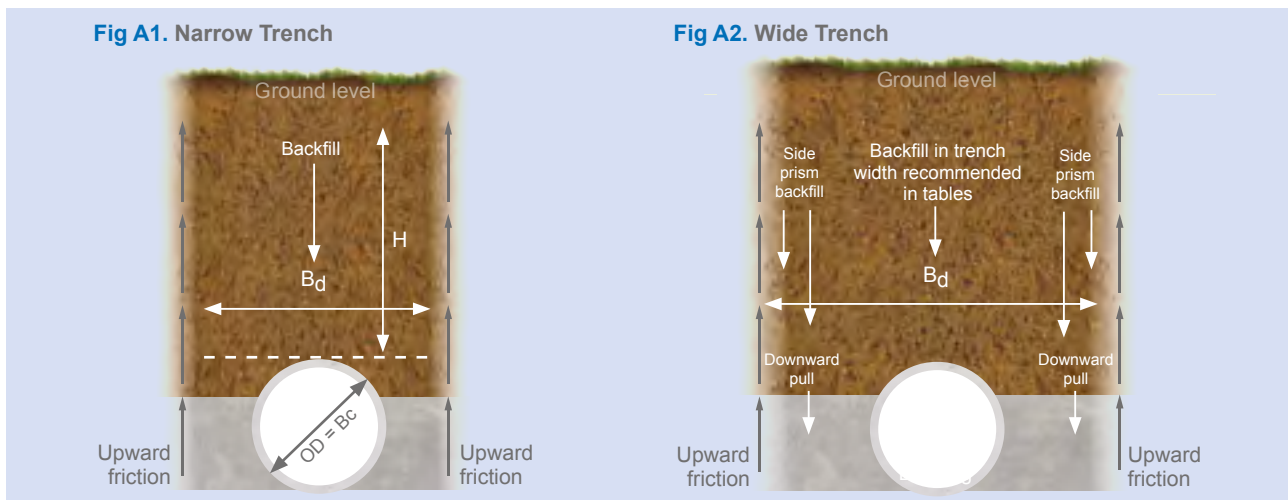

For any depth there is a trench width where friction planes from the trench walls become remote from the pipe and no longer contribute to the reduction of the fill load. In fact the settlement of the side prisms of backfill tend to increase the load (see Fig.A2). This state is called the **wide trench condition**. It is a positive projection condition. The backfill loading on the pipe does not take any relief from undisturbed ground.

The wide trench backfill load is calculated by using the Marston formula. In preparing the tables for narrow trench conditions, due consideration has been given as to whether at any trench width and depth, the narrow or wide trench condition and load is applicable, and the standard practice of using the lesser of these values has been adopted.

$$W'_c = C_c w B_d^2$$

Where:

W'_c = Backfill load (kN/m)

C_c = Soil load coefficient in wide trench conditions, dependant on soil type

Note: This can vary dependant on soil type and ratio of cover depth to trench width, however conservative standard assumptions are generally used.

w = Soil density (kN/m³)

B_c = Outside diameter of pipe (m)

The tables give the total loads for pipes of all diameters specified in BS 5911-1. This load includes loading from backfill and traffic for depths of cover over the top of the pipe as follows:

Main Roads	0.60m to 10.0m
Fields	0.60m to 10.0m

For DN 600 and above the water load shown is also included.

Table A1. Minimum crushing loads (F_n) for strength class 120 units with a circular bore for use in a trench – BS 5911-1:2002+A2:2010.

Nominal Size DN	Minimum crushing Load kN/m
225	27
300	36
375	45
400*	48
450	54
500*	60
525	63
600	72
675	81
700*	84
750	90
800	96
825	99
900	108
1000*	120
1050	126
1200	144
1350	162
1400	168
1500	180
1600	192
1800	216
2000	240
2100	252
2200*	264
2400*	288

NOTE 1 Classic sizes, denoted by an asterisk, will be phased out if called for by further European harmonisation.
NOTE 2 Sizes DN 225 to DN 600 inclusive are normally only manufactured unreinforced in the United Kingdom.
NOTE 3 Sizes DN 1000 and above are normally only manufactured reinforced in the United Kingdom.
NOTE 4 Table NA.5 of BS EN 1295-1: recommends that the minimum value of safety factor for the structural design of reinforced pipelines should be increased from the normal 1.25 to 1.5 if, as is the case of BS EN 1916: 2002, the proof load is 67% of the minimum crushing load.
* Sizes marked with asterisk are not readily available in the UK

1.2.4 Pipe Bedding

The load bearing capacity of an installed pipeline relates directly to the construction of the bedding which is intended to level out any irregularities in the formation, and provide uniform support around and along the length of the pipe barrel.

Pipe settlement will be kept to a minimum by the proper selection and compaction of the bedding material. The bedding should be compacted to a density not less than that of the natural soil in the sides and bottom of the trench. The bedding directly beneath or above the pipeline must not be over compacted otherwise line loading of the pipes will result.

On steep gradients, or where dewatering has taken place, it is important to restrict ground water movement within the completed trench. Selection of bedding or clay dams across the full width of the trench will assist in this.

Under no circumstances should blocks or bricks be placed beneath pipes. Any pegs used for setting out or levelling must be removed.

Bedding materials

Any stable soil will act adequately as a bedding material provided that it is placed and compacted around the pipeline. From a practical point of view granular material is compacted more readily and has become widely accepted.

The bedding material should be of similar particle size to that in the trench sides. Where the ground is clay or silt, bedding material must consist of all-in gravels to prevent the trench from becoming a drainage channel and carrying away fines from the trench walls and bedding and causing settlement of the pipes.

Granular bedding material

The ideal is crushed rock or gravel but similar locally available material having an angular or an irregular shape may be used. Rounded single sized material is not recommended as it may not provide a stable bed especially for heavy larger diameter pipes.

Water Research Centre (WRc) Information and Guidance Note (IGN) 4-08-01 provides guidance on the particle size of material relating to pipe diameter.

Sands containing an excess of fine particles are more difficult to place and compact and will require a greater degree of supervision on site to achieve a stable embedment for the pipeline.

Selected bedding and fill material

This should consist of uniform readily compactable material, free from tree roots, vegetable matter, building rubbish and frozen soil. When used as fill, the material should not contain large clay lumps or cobbles. When used as bedding, all clay lumps should be excluded.

“As dug” material may be used provided that it is readily compactable and provides stable embedment.

Classes of bedding and bedding factors

The strength of an installed pipeline depends on a combination of the strength of the pipe and the class of bedding.

The selection of the bedding class is influenced by many factors, which include the nature of the ground, the loads acting on the pipeline in the trench, strength class of pipe, and the local cost and availability of the bedding material.

Taking into account the cost of labour, it is generally more economical to lay the pipes on a bedding of non-cohesive materials, or alternatively scarify the trench bottom rather than hand trim the formation.

Normally loading calculations are made considering the pipeline in complete lengths, between manholes. The calculated installation condition to satisfy the most severe loading condition between each pair of manholes is then used throughout the length.

The normally accepted classes of pipe bedding are shown in Table A2 and in Fig A3.

Table A2. Types of Bedding

Bedding Class	Bedding factor	Description	Suitability
Class D	1.1	Hand trimmed flat bottom/ formation	Fine grained soils, relatively dry conditions
Class N	1.1	Flat bed of granular all- in or selected material	Rock, mixed soils
Class C	1.5	Shaped formation (or scarify)	Uniform soils relatively dry
Class F	Narrow 1.5 Wide 1.9	Shaped bedding of granular material	General
Class B	Narrow 1.9 Wide 2.3-2.8	180° granular bedding material	General
Class S	Narrow 2.2 Wide 2.3-2.8	Complete surround of non-cohesive granular bedding material	General
Class A Plain	2.6	Plain concrete cradle	Seldom necessary Higher strength pipe with granular bedding is more practicable and economic option
Class A reinforced	3.4	Reinforced concrete cradle	
Geotextiles Where appropriate, geotextiles may be used to contain bedding materials e.g. in running sand.			

Fig. A3. Types of bedding

Class D

Hand trimmed flat bottom. Bedding factor = 1.1

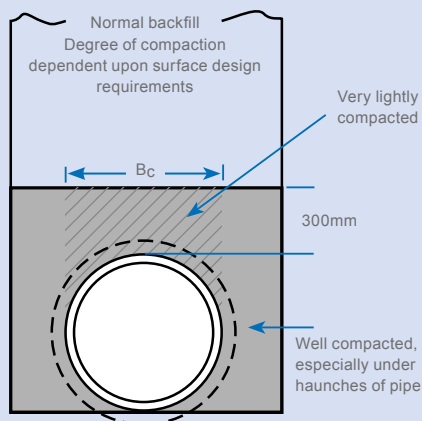

Suitable in fine grained soils and relatively dry conditions. Hand trim formation filling in any hollows. From socket holes as appropriate with 50mm minimum clearance of sufficient length to permit jointing. Pipes are laid directly on the formation.

Class N

Flat granular layer. Bedding factor = 1.1

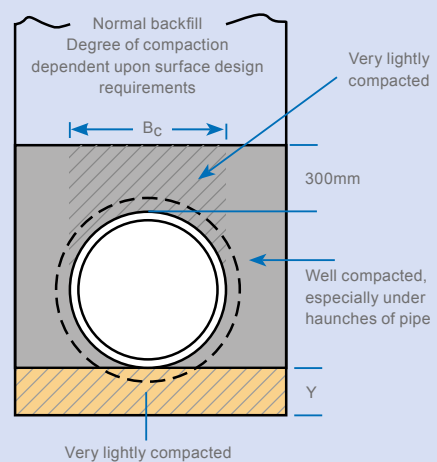

Lay pipes on a flat layer of all-in or selected material (see Note1)

Class C

Hand shaped bottom. Bedding factor = 1.5

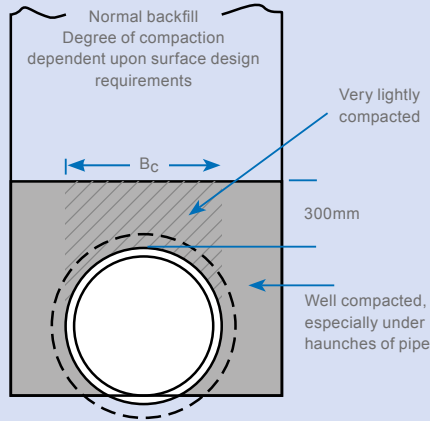

Suitable in uniform soils and relatively dry conditions. Bottom of the trench, or formation, profiled to fit barrels over a width of not more than $1/2 B_c$ with socket holes to give at least 50mm clearance under the sockets of sufficient length to permit jointing*

* Scarifying formation is generally adequate in practice

Class F

Granular Bedding

Narrow = 1.5 Wide = 1.9

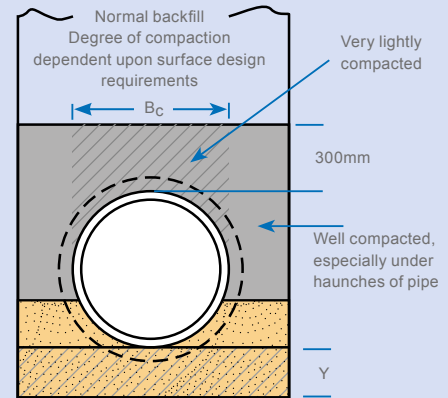

Lay pipes on a flat layer of granular bedding material on the formation, (see Note1). Scoop out socket holes with 50mm minimum clearance; lay joint pipes which will settle slightly in to the bedding. Sidefill, placed and well compacted in layers.

Class B

180° Granular bedding

Bedding factor

Narrow = 1.9

Wide DN < 0.75 = 2.5, DN > 0.75 = 2.33-2.8

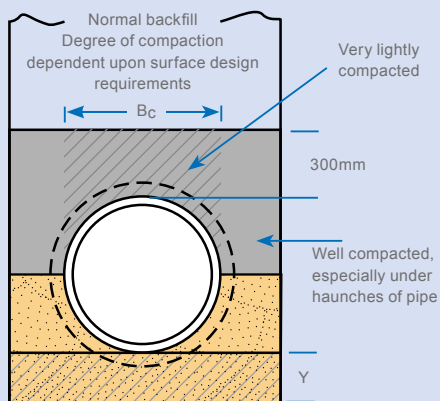

Lay pipes on a layer of granular bedding material on the formation, (see Note1). Scoop out socket holes, lay and joint pipes, place and well compact layers in the same bedding material at each side of pipes, up to springing level, taking care not to displace them.

Class S

360° Granular bedding & surround.

Bedding factor

Narrow = 2.2

Wide DN < 0.75 = 2.5, DN > 0.75 = 2.33-2.8

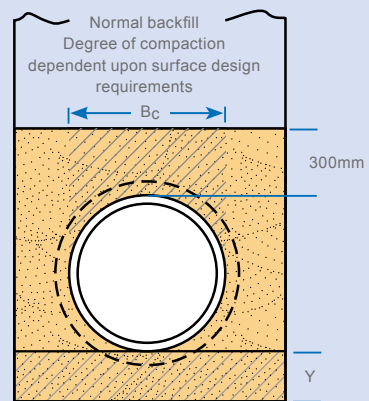

Lay, joint and bed pipes as for Class B then place bedding material at each side, up to crown level, taking care not to displace the pipes. This is followed by 300mm of granular bedding material but lightly compacted directly over the pipe, after which ordinary backfilling is commenced.



Normal backfill



Granular material



Selected backfill material



Grade C20 concrete

Class A

Plain concrete cradle. Bedding factor = 2.6

Reinforced concrete cradle. Bedding factor = 3.4

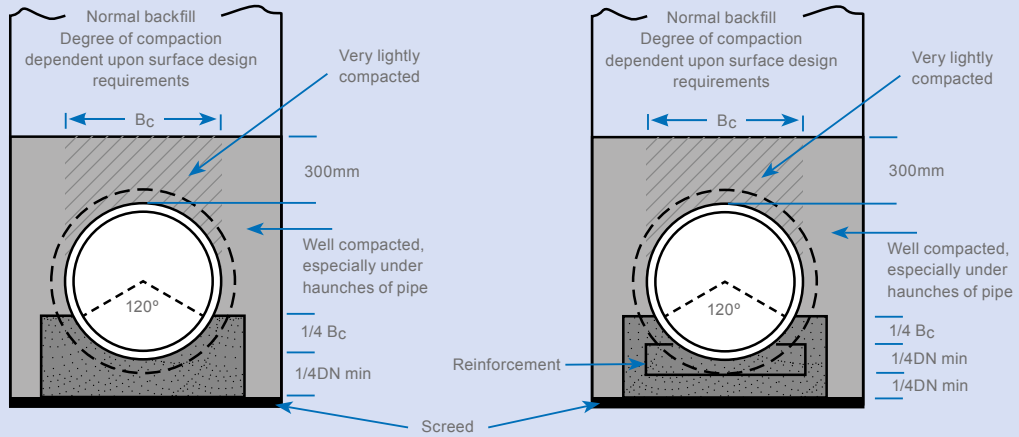

Class A concrete bedding, either plain or reinforced each 120° cradle. Screed the formation, place blocks to support pipes behind each socket. Lay pipes, using packers on blocks to achieve correct line and level. At pipe joints, form construction joints through concrete bed ensure flexibility of pipeline. Minimum width of cradle 1 1/4 B_C or B_C plus 200mm. Minimum thickness 1/4 DN min Pour concrete carefully from one side to prevent voids. Backfill when concrete has attained required strength.

NOTES:

1. Generally thickness of bedding (Y), minimum of 100mm under barrels and 50mm under sockets. In rock 200mm under barrels and 150mm under sockets subject to maximum of 400mm.
2. Sidefills, whether of bedding material or of selected material, must be well consolidated.
3. Backfill material to be compacted to 300mm above the crown (only lightly compacted directly over the pipe).
4. Normal backfill to be compacted as appropriate.
5. With reasonable workmanship and supervision these bedding factors are conservative.
6. For reinforced cradle, the minimum transverse steel area should be not less than 0.4% of the concrete in longitudinal section.

1.2.5 Design Calculations

The calculated load “W_e”, which is the total load a concrete pipe in a trench is required to sustain, is used in the design formula as follows:

$$F_m = \frac{W_e \times F_{se}}{F_n}$$

Where	F_m	=	Bedding factor required
	W_e	=	Load from Tables A3 or A4 (kN/m)
	F_{se}	=	Factor of safety
	F_n	=	BS 5911-1 test strength

Test strength of pipe (F_n)

The test strength of a concrete pipe may be referred to as F_C or F_n

In the UK, standard circular pipes to BS EN 1916 and BS 5911-1 are usually to Class 120. To calculate the test strength apply 120 x pipe nominal diameter in metres e.g. for DN450 pipe, F_n=120 x 0.45=54kN/m (see Table A1).

For a reinforced concrete pipe F_C is the load which the pipe will sustain without developing a crack exceeding 0.30mm in width over a length of 300mm and W_t is the load which the pipe will sustain without collapse, irrespective of crack width. However, to further simplify the procedure it is more straightforward to use the maximum test load F_n and applying the factor of safety of F_{se}.

Table A3. Road Loading. “H” = 0.6 metres to 10.0 metres

Nominal Diameter DN (mm)	Outside Diameter BC (mm)	Recommended maximum trench width Bd (m)	Total design load (We) in kN/m for cover depths ‘H’ in metres - Main Road																						
			0.6	0.8	1.0	1.2	1.4	1.6	1.8	2.0	2.2	2.4	2.6	2.8	3.0	3.5	4.0	4.5	5.0	5.5	6.0	7.0	8.0	9.0	10.0
225	295	0.70	41	35	32	29	29	29	28	29	30	31	31	33	33	34	35	36	36	37	37	38	38	39	39
300	412	0.85	57	49	45	42	41	40	41	42	42	43	44	44	45	47	48	50	51	52	53	54	56	57	57
375	493	1.05	68	58	53	50	49	48	49	50	51	52	54	56	58	61	63	66	69	71	72	76	79	80	82
450	581	1.15	81	68	61	59	57	57	57	58	59	62	63	65	66	69	72	76	78	81	84	87	91	94	95
525	675	1.20	94	78	72	69	67	66	67	67	68	69	70	71	73	76	79	83	86	89	91	96	99	102	104
600	776	1.35	108	90	81	77	76	76	76	77	79	81	81	82	84	89	93	97	100	104	107	114	119	123	127
675	849	1.45	118	99	89	84	83	84	85	85	86	88	89	91	93	97	102	107	112	115	119	127	134	139	143
750	962	1.50	134	111	100	94	92	92	91	92	93	94	95	96	99	103	108	113	118	122	127	134	141	147	152
800/825	975	1.60	136	114	102	96	95	94	96	97	98	99	102	104	105	111	117	123	128	133	138	147	155	163	168
900	1080	1.90	151	126	113	107	104	104	106	110	113	117	120	123	126	134	143	151	159	166	173	187	198	208	218
1050	1262	2.10	177	147	131	124	120	120	121	125	130	135	138	141	144	153	163	172	182	190	199	215	229	242	253
1200	1447	2.30	203	169	151	142	137	136	137	141	146	151	156	159	163	174	184	195	205	216	225	244	261	278	291
1350	1620	2.50	230	191	171	160	154	153	154	157	163	168	173	178	182	193	205	218	230	243	254	276	295	314	331
1500	1803	2.70	256	213	191	178	171	170	170	174	179	184	191	196	202	213	227	240	254	268	280	306	329	350	369
1600	1920	2.85	274	228	204	190	184	181	182	184	190	196	204	211	214	228	244	257	272	287	301	329	354	376	390
1800	2150	3.10	302	251	225	210	203	199	199	203	209	215	222	231	239	255	271	287	304	319	336	368	397	424	449
2100	2485	3.40	359	299	267	250	240	236	235	239	244	252	259	266	273	289	307	326	344	363	383	417	452	483	515
2400	2795	3.70	409	342	305	286	274	269	269	272	277	284	292	301	307	325	344	365	387	407	428	468	507	544	580

Table A4. Field Loading. "H" = 0.6 metres to 10.0 metres

Nominal Diameter in mm	Outside Diameter in mm	Recommended Trench width in m	Total design load (We) in kN/m for cover depths 'H' in metres - Field loading																						
			0.6	0.8	1.0	1.2	1.4	1.6	1.8	2.0	2.2	2.4	2.6	2.8	3.0	3.5	4.0	4.5	5.0	5.5	6.0	7.0	8.0	9.0	10.0
225	295	0.70	26	21	20	18	19	19	19	21	22	24	24	26	27	28	30	31	32	33	33	35	35	36	36
300	412	0.85	36	29	27	26	26	26	26	28	29	30	32	33	34	35	38	40	42	44	45	46	49	50	52
375	493	1.05	42	35	32	31	31	32	32	33	35	37	38	41	43	46	50	54	57	60	63	65	69	72	76
450	581	1.15	50	41	38	36	36	37	39	41	43	46	49	51	52	57	61	65	69	72	75	80	84	87	90
525	675	1.20	58	48	43	42	42	43	45	46	48	50	52	54	56	61	65	70	73	77	80	86	90	94	97
600	776	1.35	69	57	52	51	50	52	54	56	58	60	62	64	67	73	79	84	89	93	98	105	111	116	120
675	849	1.45	76	63	57	55	55	57	59	61	63	66	68	71	74	80	87	93	99	104	108	117	124	130	135
750	962	1.50	86	71	65	64	64	61	63	62	67	70	72	75	78	85	91	98	104	109	115	123	131	138	144
800/825	975	1.60	88	73	66	64	64	64	65	67	70	72	75	78	81	84	92	100	106	113	120	126	136	145	160
900	1080	1.90	97	81	74	72	71	73	77	80	84	89	94	98	102	113	123	133	142	150	158	174	187	198	208
1050	1262	2.10	114	95	87	84	84	86	90	94	99	103	108	113	117	129	140	152	163	173	183	201	217	230	243
1200	1447	2.30	132	110	101	97	97	99	103	107	112	116	121	126	132	145	158	171	184	196	207	228	247	264	279
1350	1620	2.50	148	123	113	109	110	112	115	119	124	129	134	140	146	161	177	191	205	219	232	256	278	298	316
1500	1803	2.70	165	139	126	122	122	124	127	131	136	142	148	155	162	178	195	211	227	242	257	285	310	333	354
1600	1920	2.85	177	148	135	131	130	132	135	140	146	153	159	166	173	190	209	225	244	260	276	307	333	368	382
1800	2150	3.10	200	167	153	148	147	147	152	156	164	170	177	186	193	213	233	253	272	290	308	343	375	404	431
2100	2485	3.40	234	197	179	172	169	170	173	181	187	193	201	210	219	240	263	286	307	329	351	389	426	460	494
2400	2795	3.70	266	224	204	194	191	193	198	202	210	219	227	237	246	271	295	320	345	369	392	436	478	518	555

1.2.6 Worked examples

The symbols used in the examples are those referred to in Design Calculations (Section 1.2.5).

Example 1

Size of pipe: DN900 (reinforced) Cover depth:3.00m Design load: Main road

Nominal Diameter DN (mm)	Outside Diameter BC (mm)	Recommended maximum trench width Bd (m)	Total design load (We) in kN/m for cover depths 'H' in metres - Main Road																											
			0.6	0.8	1.0	1.2	1.4	1.6	1.8	2.0	2.2	2.4	2.6	2.8	3.0	3.5	4.0	4.5	5.0	5.5	6.0	7.0	8.0	9.0	10.0					
225	295	0.70	41	35	32	29	29	29	28	29	30	31	31	33	33	34	35	36	36	37	37	38	38	39	39					
300	412	0.85	57	49	45	42	41	40	41	42	42	43	44	44	47	47	48	50	51	52	53	54	56	56	57					
375	493	1.05	68	58	53	50	49	48	49	50	51	52	54	56	58	61	63	66	69	71	72	76	79	80	82					
450	581	1.15	81	68	61	59	57	57	57	58	59	62	63	65	68	69	72	76	78	81	84	87	91	94	95					
525	675	1.20	94	78	72	69	67	66	67	67	68	69	70	71	73	76	79	83	86	89	85.7	96	99	102	104					
600	776	1.35	108	90	81	77	76	76	76	77	79	79	81	82	84	89	93	97	100	104	107	114	119	123	127					
675	849	1.45	118	99	89	84	83	84	85	85	86	88	89	91	93	97	102	107	112	115	119	127	134	139	143					
750	962	1.50	134	111	100	94	92	91.4	91	92	93	94	95	96	99	103	108	113	118	122	127	134	141	147	152					
800/825	975	1.60	136	114	102	96	95	94	96	97	98	99	102	104	105	111	117	123	128	133	138	147	155	163	168					
900	1080	1.60	161	126	113	107	104	104	105	106	108	112	117	120	123	126	134	143	151	159	166	173	187	198	208	218				
1050	1262	2.10	177	147	131	124	120	120	121	125	130	135	138	141	144	153	163	172	182	190	199	215	229	242	253					
1200	1447	2.30	203	169	151	142	137	136	137	141	146	151	156	159	163	174	184	195	205	216	225	244	261	278	291					
1350	1620	2.50	230	191	171	160	154	153	154	159	164	170	175	178	182	194	205	216	227	238	248	270	288	306	320					
1500	1803	2.70	256	213	191	178	171	170	171	176	182	188	194	198	202	215	227	238	249	260	271	294	313	331	345					
1600	1920	2.85	274	228	204	190	184	183	184	189	195	201	207	211	215	229	241	252	263	274	285	309	328	346	360					
1800	2150	3.10	302	251	225	210	203	199	200	205	211	217	223	227	231	246	258	269	280	291	303	328	347	365	379					
2100	2485	3.40	359	299	267	250	240	235	236	241	247	253	259	263	267	283	295	306	317	328	341	367	386	404	418					
2400	2795	3.70	409	342	305	286	274	268	269	274	280	286	292	296	300	317	329	340	351	362	375	401	420	438	452					

From Table, W_e (total design load) = 126kN/m
 $F_{se} = 1.5$ (DN > 0.6 reinforced pipe)
 Pipe strength = $120 \times 0.9 = 108\text{kN/m}$
 Bedding factor required (F_m) = $W_e \times F_{se} / F_n = 126 \times 1.5 / 108 = 1.75$
 From Table A2, Bedding Class B ($F_m = 1.9 > 1.75$) and Class S ($F_m = 2.2 > 1.75$) are suitable
Provide Class B or S bedding. Maximum trench width = 1.9m

Example 2

A 900mm diameter pipeline with Class B bedding is to be laid across fields.

What is the greatest cover depth that these pipes may be laid?

Nominal Diameter in mm	Outside Diameter in mm	Recommended Trench width in m	Total design load (We) in n kN/m for cover depths 'H' in metres - Field loading																											
			0.6	0.8	1.0	1.2	1.4	1.6	1.8	2.0	2.2	2.4	2.6	2.8	3.0	3.5	4.0	4.5	5.0	5.5	6.0	7.0	8.0	9.0	10.0					
225	295	0.70	26	21	20	18	19	19	19	21	22	24	24	26	27	28	30	31	32	33	33	35	35	36	36					
300	412	0.85	36	29	27	26	26	26	28	29	30	32	33	34	35	38	40	42	44	45	46	49	50	51	52					
375	493	1.05	42	35	32	31	31	32	33	35	37	38	41	43	46	50	54	57	60	63	65	69	72	75	76					
450	581	1.15	50	41	38	36	36	37	39	41	43	46	49	51	52	57	61	65	69	72	75	80	84	87	90					
525	675	1.20	58	48	43	42	42	43	45	46	48	50	52	54	56	61	65	70	73	77	80	86	90	94	97					
600	776	1.35	69	57	52	51	50	52	54	56	58	60	62	64	67	73	79	84	89	93	98	105	111	116	120					
675	849	1.45	76	63	57	55	55	57	59	61	63	66	68	71	74	80	87	93	99	104	108	117	124	130	135					
750	962	1.50	86	71	65	64	61	61	63	62	67	70	72	75	78	85	91	98	104	109	115	123	131	138	144					
800/825	975	1.60	88	73	66	64	64	65	67	70	72	75	78	81	84	92	100	106	113	120	126	136	145	153	160					
900	1080	1.60	97	81	74	72	71	72	73	77	80	84	88	91	98	102	109	113	120	126	136	145	153	160	168					
1050	1262	2.10	114	95	87	84	84	84	86	89	93	97	101	104	108	117	123	130	136	146	155	164	173	182	191					
1200	1447	2.30	132	110	101	97	97	97	99	102	106	110	114	117	121	130	137	144	154	163	172	181	190	199	208					
1350	1620	2.50	148	123	113	109	110	110	112	115	119	123	127	130	134	143	150	158	167	176	185	194	203	212	221					
1500	1803	2.70	165	139	126	122	122	122	124	127	131	135	139	142	146	155	162	170	179	188	197	206	215	224	233					
1600	1920	2.85	177	148	135	131	130	130	132	135	139	143	147	150	154	163	170	178	187	196	205	214	223	232	241					
1800	2150	3.10	200	167	153	148	147	147	149	152	156	160	164	167	171	180	187	195	204	213	222	231	240	249	258					
2100	2485	3.40	234	197	179	172	169	169	171	174	178	182	186	189	193	202	210	218	227	236	245	254	263	272	281					
2400	2795	3.70	266	224	204	194	191	191	193	196	200	204	208	211	215	224	232	240	249	258	267	276	285	294	303					

$F_{se} = 1.5$ (DN > 0.6 reinforced pipe)
 Pipe strength = $120 \times 0.9 = 108\text{kN/m}$
 Bedding factor provided (F_m) = 1.9
 Maximum design external load $W_e = F_m \times F_n / F_{se} = 1.9 \times 108 / 1.5 = 136.8\text{kN/m}$
 From Table A4, Total load at 4.5m = 133 kN/m
 Total load at 5.0m = 142kN/m.
 By interpolation
Maximum permissible depth H = 4.7m / Maximum trench width = 1.9m



BDPA has developed online Structural and Material Cost calculators and a web App to help with the calculation and optimisation of the structural design and material cost of underground sewer pipeline systems.

The App offers a two-stage process:

Stage 1 Structural Design Calculator enables users to quickly establish acceptable structural bedding Classes for buried pipes based on the recommendations in BS EN 1295-1 "Structural design of buried pipelines".

Stage 2 Material Cost Calculator where users can compare the cost of materials required for each bedding Class option. The calculator takes into account the pipe cost (including connectors, gaskets, etc), imported granular bedding material and the disposal of surplus excavated material removed from the trench.



The App not only helps to improve pipeline construction cost efficiency by enabling users to minimise the amount of expensive imported granular bedding used during construction, it can also reduce the embodied carbon of the installation.

1.3 MANHOLE DESIGN

1.3.1 Manhole Positions

Manholes are recommended:

- At intervals of up to 90m, or 200m for man entry pipe runs.
- Whenever there is a significant change of direction in a sewer.
- Where another sewer is connecting with the main run of a sewer.
- Where there is a change of size or gradient of pipeline.
- Where there is a change of design loading or bedding design.

1.3.2 Precast Components

The following standard precast concrete components are manufactured in accordance with BS EN 1917 & BS 5911-3 for assembly into complete manholes;

- Adjusting units and corbel slabs
- Cover slabs
- Shaft sections
- Reducing slabs
- Chamber sections
- Landing slabs
- Base units

Fig. A4. Typical Manhole Layout

Fig. A4a. Typical Cast In-situ Manhole Base with Tongue and Groove Jointed Rings

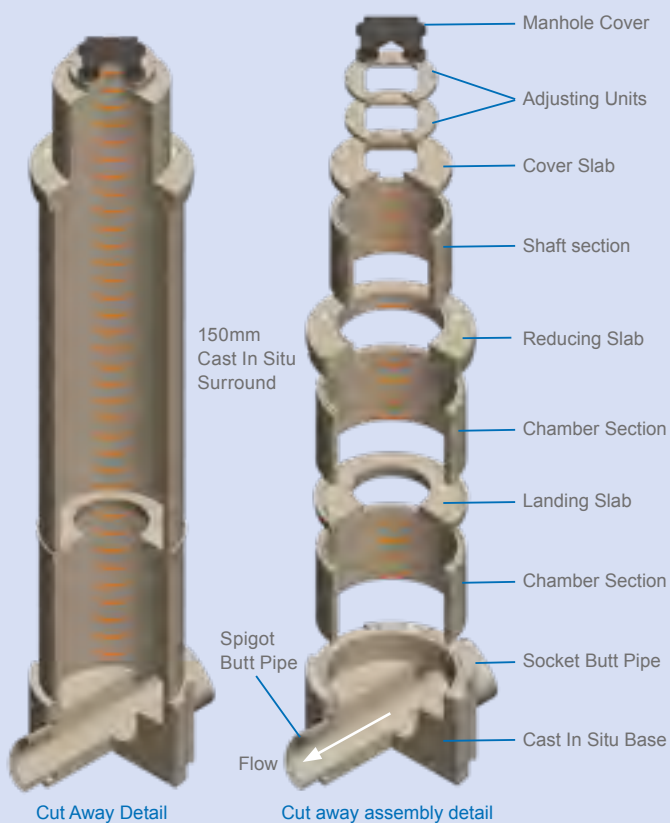
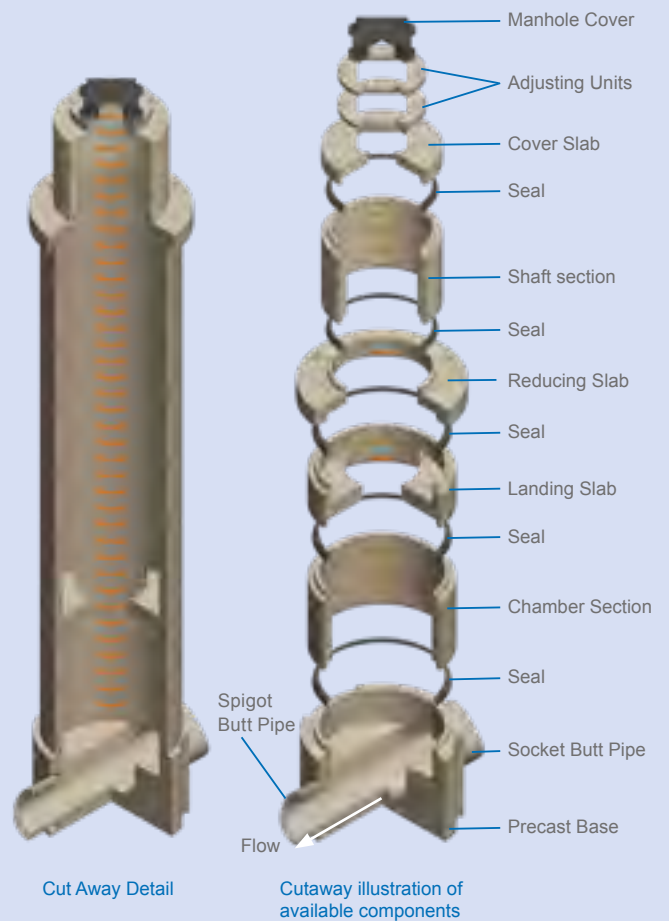

Fig. A4b. Typical Precast Manhole Base with Elastomeric Seal Jointed Rings



Base units can be supplied with circular or semicircular holes (cut-outs or 'dog kennels') cut in the chamber walls or with factory made flexible joints to incorporate a sealing ring to connect pipes to the chamber.

1.3.3 Advantages

The main advantages of manholes using precast concrete components are:

1. Reduced construction time and cost
2. Less operative risk exposure in trench during construction
3. Its self-weight provides natural resistance to flotation
4. Can accommodate new build and retro-fitting of new connections
5. Units are produced in a controlled factory environment to BS EN 1917 & BS 5911-3 to ensure consistent quality and performance.
6. All BPDA member factories are licensed to manufacture 'Kitemarked' standard units under BS EN ISO 9001 quality management systems.
7. They are manufactured in a range of standard sizes and depths.
8. They are simple to assemble requiring relatively unskilled labour on site.
9. Units are watertight structures without the need for a concrete surround. Soil backfill is normally sufficient.
10. They can be supplied ready fitted with double steps complying with BS EN 13101.
11. The structure is durable with its own inherent strength.

1.3.4 Types of Manholes

Manholes should be designed and constructed in accordance with BS EN 752. Table NA.22 provides recommendations for dimensions for manholes and manhole shafts for UK applications (with personnel entry) and Sewers for Adoption provides details of manholes suitable for adoption purposes.

Manholes are built on a run of sewer with or without side connections. Where conditions permit, the soffit level of sewers connecting to a manhole should be the same.

Manholes may be constructed with or without a shaft. It is recommended that reducing slabs and shafts are only used for DN1800 manholes and larger. Landing slabs are generally required for manholes 6 metres deep or greater.

Smaller diameter chambers should be constructed up to full height and use a cover slab. There are also inspection chambers which are constructed over a subsidiary drain or sewer of not more than DN 225 to permit inspection and access for rodding. Most manholes are sited symmetrically over the main sewer pipeline. Side-entry manholes which are formed integral to the crown of the pipe are also manufactured. These can be advantageous in terms of installation time and cost savings.

When contemplating the installation of rectangular or square manhole/s, reference should be made to Annex F of BS 5911-3+A1.

1) Precast base systems

Inlet(s) and outlet positions are configured to site requirements and delivered with all channels and benching complete. Watertight joints and thicker walls means units do not require a concrete surround, unless specified. A faster, safer, higher quality, lower installed cost and reduced carbon footprint alternative to conventional manholes, (the product's finish is not subject to the skills of site operatives).

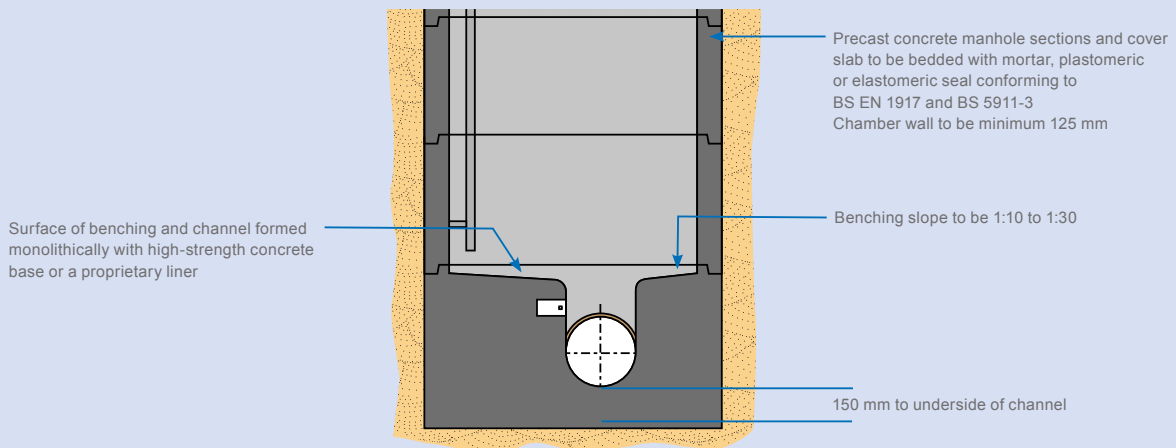

2) In-situ manholes

Concrete base, channel/s and benching installed in-situ. With the bottom section of the first manhole ring being built in to the base concrete by a minimum of 75mm. Distance between top of pipe and underside of first manhole ring to be minimum of 50mm to a maximum of 300mm. Generally and in accordance with 'Sewers For Adoption' a concrete surround is required with this type of manhole construction.

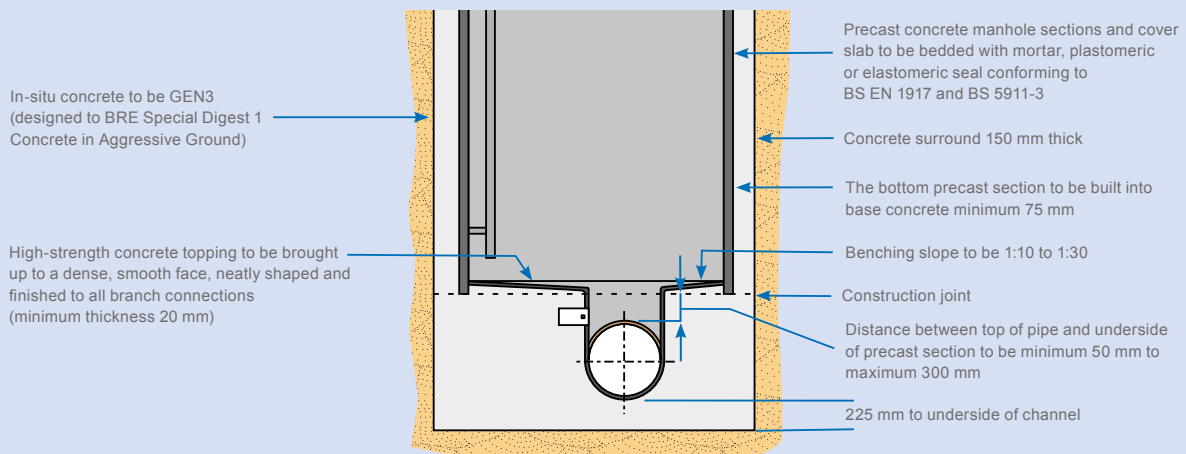

For more information on precast manhole base systems, refer to BPDA and member product information:

Marshall's CPM <http://www.cpm-group.com/products/drainage/sealed-manholes/the-perfect-manholes>

FP McCann Ltd <http://fpmccann.co.uk/easi-base>

Stanton Bonna <http://www.stanton-bonna.co.uk/drainage-systems/watertight-manhole-system/>

BPDA <https://www.precastdrainage.co.uk/page/precaster-manhole-design-construction>

3) Side-entry manholes

Side-entry can be provided for sewers larger than DN 1200. The side-entry shaft is fitted to the main sewer pipe by the manufacturer before delivery.



4) Backdrop manholes

Where one sewer connects with another at a substantially different level, the manhole is built on the lower sewer and incorporates a vertical or ramped drop pipe from the higher sewer. The drop pipe, which may be inside or outside the manhole chamber, has its lower end discharging into the main sewer, and at its upper end has a rodding eye for cleaning through the higher sewer.

Wherever possible, steeper gradients are preferred over the use of backdrops in 'Sewers For Adoption'.

5) Dual and crossing manholes

Where surface water and foul sewers are laid in the same trench, the surface water being normally above the foul, a normal manhole chamber is built for the foul sewer and the surface water is carried across the chamber in a separate pipe which may have a sealed inspection cover.

1.3.5 Sizes of Manholes

The diameter of the chamber is determined by the number and the diameter of the sewer pipes coming into the manhole and the working space required.

The chamber should be a minimum of DN 1050 and is the smallest size that may be fitted with steps, but are only permitted to be used to a depth of 1.5m. DN 1200 is the smallest size that can be used deeper than 1.5m and to which ladders may be fitted. It should have ample benching at least 225mm wide on one side of the channels. On the other side, the benching should be wide enough to stand on, at least 450mm.

For deep manholes, the chamber should be large enough to provide benching or a landing adequate for two persons to stand upon.

A guide for the minimum chamber diameters required for various sizes of sewer pipes entering the manhole is given in Table A6. When a manhole is sited on a curve, or where additional pipes enter at the sides a larger size may be required.

Table A5. Sizes of pipe and manhole chamber diameters

Maximum size of pipe (DN) through chamber	Minimum Chamber diameter (DN)
Less than 375	1200
375 – 450	1350
500 – 700	1500
750 – 900	1800
Greater than 900	Pipe diameter + 900

1.3.6 Pipes Adjacent to Manholes

There may be differential settlement between a structure and the pipeline resulting in angular deflection of the joint. This creates no problem for the joint itself but when this movement is "excessive" there is a shear force that can cause structural failure on the pipe, either shear behind the collar or from beam fracture of the pipe barrel.

To prevent this, the first pipe in the line can be restricted in length. This is known as a “rocker pipe”. The likelihood of differential settlement should be assessed and rocker pipes used as appropriate.

Guidance on rocker pipes may be found in “Civil Engineering Specification for the Water Industry” and ‘Sewers for Adoption’.

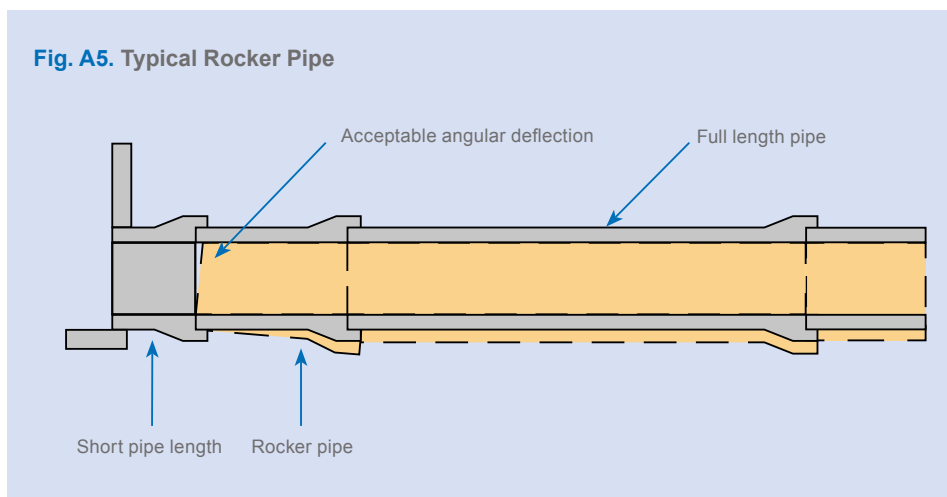

In certain conditions where excessive differential movement is possible, for pipes \geq DN750, it may be advisable to use multiple rocker pipes to avoid unacceptable angular deflection or shear force at the joint.

1.3.7 Cover, landing and reducing slabs

The minimum clear access opening for any manhole is 600 x 600mm. For manholes with depths less than 1.5m, a 1200x 675mm opening should be used.

The range of access opening sizes that are provided with precast concrete cover slabs manufactured and inspected in accordance with the scope of BS5911-3 are as follows:

Nominal chamber size (mm)	Opening Configuration	
	Size (mm)	Location
DN900	600 x 600	Central
	675 x 675	Central
DN1050	600 x 600	Eccentric
	675 x 675	Eccentric
	750 x 750	Central
DN1200, 1350 & 1500	600 x 600	Eccentric
	675 x 675	Eccentric
	750 x 600	Eccentric
	1200 x 675	Central
DN1800, 2100, 2400, 2700 & 3000	600 x 600	Eccentric
	675 x 675	Eccentric
	750 x 600	Eccentric
	1200 x 675	Eccentric
1200 x 750 rectangular	600 x 600	Eccentric
	675 x 675	Eccentric
	750 x 600	Eccentric

Generally, slabs manufactured and inspected in accordance with BS5911-3 are suitable for use in applications where an A15 - D400 rated manhole cover, manufactured and inspected in accordance with BS EN 124, is intended to be used.

In concluding the above demonstrates that the test loads required to comply with BS5911-3 are at least equivalent to the loading required under BS EN 1991-2 when considering crack width requirements. The principal difference between the cover slab product standard and the Eurocode design standard being slabs to the BS 5911-3 are tested as opposed to a structural design required for compliance with BS EN 1991-2.

Generally, slabs manufactured and inspected in accordance with BS5911-3 are suitable for use in applications where an A15 - D400 rated manhole cover, manufactured and inspected in accordance with BS EN 124, is intended to be used.

Slabs that are to be used in differing loading conditions, or with multiple access holes or access hole sizes outside of the scope of BS5911-3, can be manufactured in precast concrete but this will be a bespoke design and manufactured in accordance with the relevant Standards; i.e. they will not be tested.

Landing slabs

Landing slabs are generally required on manholes greater than 6m depth (landing slabs should be installed at minimum of 2 metres and maximum of 6 metres spacing for the depth of the manhole).

Reducing slabs

On large, deep chambers (usually DN1800 or greater), it is common practice to reduce the upper access shaft to a smaller, more economic solution of typically DN1200 size. Where double steps are fitted in the main chamber, the steps alignment is maintained through the reduced shaft section.

Nominal chamber size (mm)	Opening Configuration	
	Size (mm)	Location
Landing Slabs		
DN1800, 2100, 2400, 2700 & 3000	DN900	Eccentric
Reducing Slabs		
DN1800, 2100, 2400, 2700 & 3000	DN900	Eccentric
	DN1050	Eccentric
	DN1200	Eccentric

Adjusting units and Corbel units

Adjusting units can be installed between the concrete cover slab and the access cover and frame (can be used in replacement of engineering brickwork in most situations).

The access in the concrete cover slab may be reduced in size (typically from 750 x 600 mm to 600 x 600 mm) via the use of corbel units.

In order to meet the maximum distance from cover level to the first step (typically 675mm), it is recommended that no more than three adjusting/corbel units are used in total.

1.4. BOX CULVERTS

1.4.1 BOX CULVERT DESIGN

Introduction

Box culverts can be used for a wide variety of applications. For further information please refer to the BPDA website. Prior to the formation of the BPDA the trade body representing box culverts was the Box Culvert Association (BCA).

The design of headwalls/wingwalls/aprons is not covered in this guide. For further information please contact the BPDA member companies.

Box culverts are manufactured to BS EN 14844 +A2: 2011. This standard provides guidance on materials, durability, testing methods, geometry, tolerances, settlement, and production requirements. Figure E1 shows the geometrical terminology used for box culverts. The standard also offers references to design criteria as explained in 5.1.3. The harmonised European standard also references other standards, including the precast products Common Rules standard BS EN 13369: 2013.

Note: EN 14844 covers monolithic box culvert units only. U-shaped units or boxes consisting of more than a single element are not covered by that European standard and should be manufactured to BS EN 13369.

Figure A6. Culvert geometry / terminology

t_r roof/floor slab thickness

t_w wall thickness

e, f - geometry of the splay (refer to diagram below)

Effective roof span (W_e) = $W + t_w$

Effective wall span (H_e) = $H + t_r$

Effective and Socket inner and overlapping nibs of a rebated joint profile (refer to diagram below)

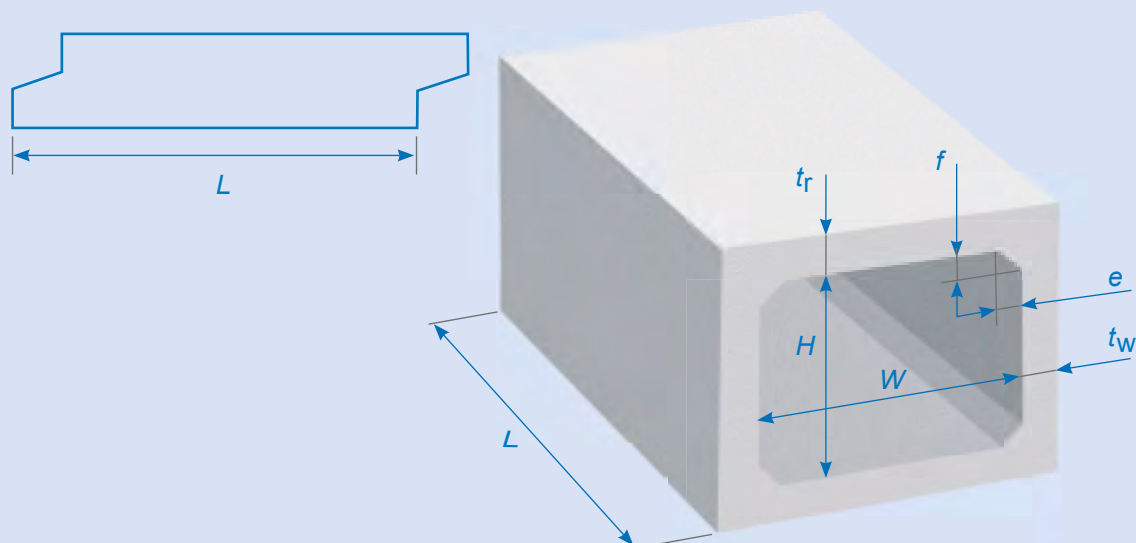

1.4.2 Box Culvert Hydraulic Design

Table A6 BPDA standard box culvert range - internal dimensions (mm) & cross-sectional flow area (m2)

Height mm (internal span)		Width mm (internal span)																											
		500	600	800	1000	1100	1200	1250	1375	1500	1750	1800	2000	2100	2250	2400	2500	2700	3000	3300	3600	3900	4200	4500	4800	5100	5400	5700	6000
300	0.15																												
400	0.24	0.32	0.38																										
500		0.46	0.56	0.59	0.71	0.86	1.01	1.01	1.19																				
550			0.56																										
600		0.53	0.65	0.71	0.83	1.01	1.19																						
625				0.826																									
650		0.61	0.74		0.93	1.13	1.32	1.52	1.71																				
700										1																			
750		0.735	0.9		1.06	1.25		1.74	1.965	2.19	2.415	2.64	2.865	3.09															
800		0.73	0.89		1.13	1.37	1.61	1.85	2.09	2.33	2.57	2.81	3.05																
1000		0.93	1.13	1.341	1.42	1.69	1.92	2.03	2.33	2.63	2.92	3.23	3.53	3.83	4.13	4.43	4.73												
1200			1.37		1.73	2.09	2.45	2.81	3.17	3.53	3.89	4.25	4.61	4.97	5.33	5.69	6.02	6.38	6.74	7.09									
1250					1.815																								
1500		1.42			2.17	2.57	2.92	3.08	3.315	3.53	3.67	3.98	4.42	4.88	5.33	5.78	6.23	6.68	7.13	7.55	8	8.45	8.9						
1800						3.17	3.71	4.25	4.79	5.33	5.87	6.41	6.95	7.49	8.03	8.57	9.08	9.62	10.16	10.7									
2000		1.92			2.92		3.92		4.92		5.92																		
2100							4.34		5.6	6.23	6.86	7.49	8.12	8.75	9.38	10.01	10.61	11.24	11.87	12.5									
2400								5.69	6.41	7.13	7.85	8.57	9.29	10.01	10.73	11.45	12.14	12.86	13.58	14.3									
2500					3.67		4.92		6.17																				
2700									7.22	8.03	8.84	9.65	10.46	11.27	12.08	12.89	13.67	14.48	15.29	16.1									
3000		2.92			4.42		5.92		8.93	9.83	10.73	11.63	12.53	13.43	14.33	15.2	16.1	17	17.9										
3300											10.82	11.81	12.8	13.79	14.78	15.77	16.73	17.72	18.71	19.7									
3600												12.89	13.97	15.05	16.13	17.21	18.26	19.34	20.42	21.5									

NOTES

- The cross-sectional area of box culverts may be useful for calculating the storage capacity of surface water drainage attenuation systems and up to full bore flow capacity in steady, uniform flow conditions. It is not advisable to use the full cross-sectional area for the hydraulic design of culverted watercourses.
- The cross-sectional areas shown in this table may vary between box culverts produced by BPDA members. The minimum value is shown and should be used for guidance only. For an accurate value of the actual cross-sectional area and the box culvert sizes available from each BPDA member, please refer to the product data published by the manufacturer.

Design principles

The overall scheme designer is responsible for the hydraulic design of a box culvert, taking into account all parameters relevant to the project.

For example:

- conditions upstream and downstream of the culvert (before and after culvert construction)
- inlet and outlet hydraulic energy losses
- compound hydraulic roughness of culvert
- longitudinal flow profiles (such as backwater, headwater and tailwater depths), afflux and freeboard through the culvert during maximum design flows
- cross-section restriction due to sediment deposition
- benching for fish / mammal passage
- low flow channel provision
- safe access and screening requirements
- appropriate maintenance regime to ensure effective performance over asset lifetime
- flood routing in the event of a blockage

BPDA members can provide discharge capacities based on flows through the full cross-section of box culvert units, i.e. full-bore flow. In practice, this is likely to over-estimate the actual capacity of the culvert and may not represent the actual conditions.

The following example, based on CIRIA Culvert design and operation guide (C689) is provided to demonstrate the basic hydraulic design process for culverts. Users should acquire the full publication or seek alternative guidance in order to carry out their own hydraulic design for projects.

Example 5.A

It is proposed to build an access road over a stream using a highway culvert under the road. The culvert is required to carry a design flood of $4.0\text{m}^3/\text{s}$ under free flow conditions with partial sedimentation. Normal flow conditions may be assumed and there are no hydraulic structures at the culvert site to consider. The bed slope S_o is gentle at 1:200 (i.e. 0.005m/m).

Design steps

- Calculate the tailwater depth at the culvert for the design flood
- Check suitability of proposed culvert dimensions

Data references

- BPDA Table of Standard box culvert dimensions (see Table A6)
- CIRIA Culvert design and operation guide (C689) Table A1.6 geometrical formulae

Manning's equation for open channel flow

$$V = n^{-1}R^{2/3}S_o^{1/2}$$

Where

V = mean velocity (m/s)

R = hydraulic radius (m) = A/P

A = cross-sectional area of flow (m^2)

P = wetted perimeter (m)

S_o = slope of energy line (bed slope)

n = coefficient of roughness (Manning's n)

For any flow, the discharge Q at a channel section is expressed by

$$Q = VA$$

Where

Q = flow rate (m³/s)

V = mean velocity (m/s)

A = cross-sectional area of flow (m²)

i) Tailwater depth

The stream has a trapezoidal cross-section, see below. Use Manning's equation for normal flow (assume n = 0.035) to estimate the tailwater depth at the culvert location.

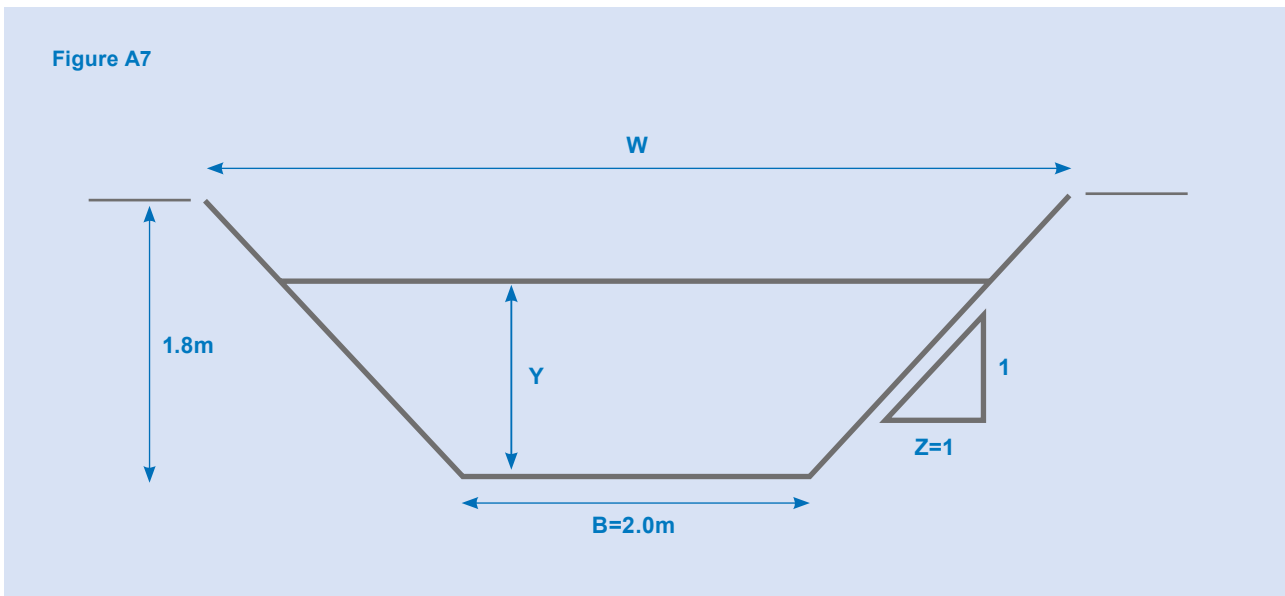

The initial estimates for tailwater depth based on the geometrical properties and flows are given in the table below.

Table A7

B	2					
z	1					
So	0.005					
n	0.035					
Tailwater depth y (m)	Cross-sectional flow area A (m ²) (B + zy)y	Wetted perimeter P (m) B + 2y√(1+z ²)	Hydraulic Radius R (m) (B+zy)y/B+2y√(1+z ²)	R ^{2/3}	So ^{1/2}	Flow Q (m ³ /s) AR ^{2/3} So ^{1/2} /n
0.80	2.24	4.26	0.53	0.34	0.07	1.55
1.20	3.84	5.39	0.71	0.57	0.07	4.40
1.10	3.41	5.11	0.67	0.51	0.07	3.51
1.15	3.62	5.25	0.69	0.54	0.07	3.94
1.16	3.67	5.28	0.69	0.54	0.07	4.03*
*Closest to 4.0m ³						

Use tailwater depth $y_{dc} = 1.15\text{m}$.

Figure which results is flow Q nearest to the design flow of $4.0\text{m}^3/\text{s}$.

ii) Culvert sizing

The developer intends installing a 2.7m wide by 1.8m high precast concrete box culvert with the invert below bed level to allow for the formation of a natural bed and re-grading of the stream. Is the proposed culvert suitable? Can any improvements be made?

Step 1.

Estimate the required culvert size using the barrel velocity method. Calculate velocity in the downstream channel V_{dc} (use area from (i)).

$$V_{dc} = Q/A = 4.0/3.6 = 1.1\text{m/s}$$

Step 2.

Calculate the required culvert flow area assuming that the barrel velocity is 10% higher than the downstream channel. (N.B. It is generally considered good practice for the channel flow velocity to be greater within the culvert).

$$A = Q/(1.1 \times V_{dc}) = 4.0/(1.1 \times 1.1) = 3.31\text{m}^2$$

Step 3

Estimate the freeboard (F) and sedimentation depth (S). Then determine the overall culvert height (H) for free flow conditions by adding these to the tailwater depth y_{dc} from (i).

Assume F and S are both 0.25m .

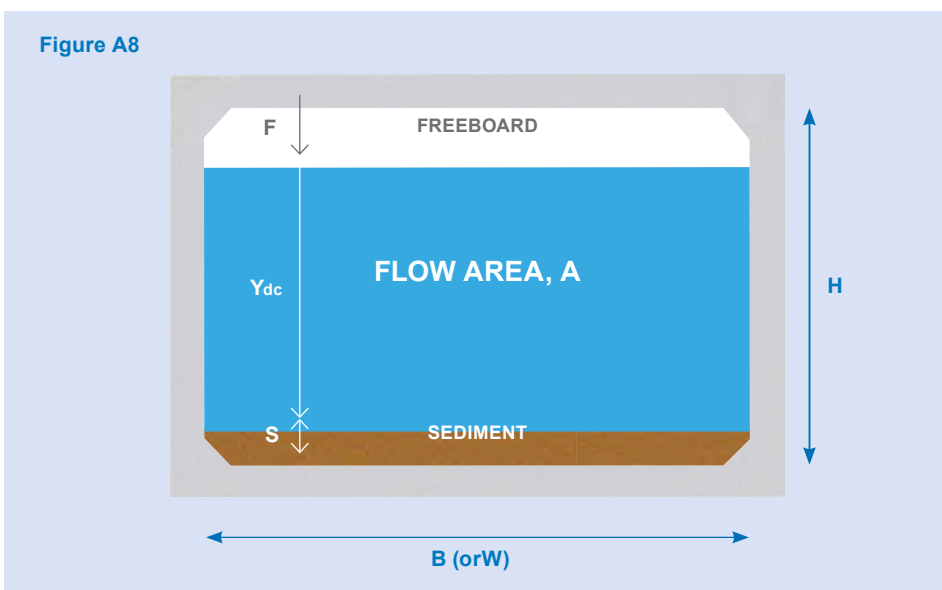

$$H = y_{dc} + F + S = 1.15 + 0.25 + 0.25 = 1.65\text{m}$$

Step 4

Estimate the culvert width B to give the required flow area. (N.B. It is common in hydraulic design for the channel width to be termed "B". Box culvert manufacturers usually refer to the culvert width as "W"). Check for suitable sizes of box culvert from the Table of standard box culvert dimensions (page 40).

$$B = A/y_{dc} = 3.31/1.15 = 2.88\text{m}$$

A 2.88m wide by 1.65m high box culvert would be acceptable, but it is not a Standard size.

The nearest Standard size is 2.7m wide by 1.8m high or 3.0m wide by 1.8m high.

Step 5

The proposed 2.7m wide by 1.8m high box culvert is suitable. The soffit of the culvert will be below the top of the bank of the stream when units are set 0.25m below the invert level of the stream (i.e. sedimentation depth, S). The barrel of the culvert is wider than the natural channel at invert level but narrower at water level.

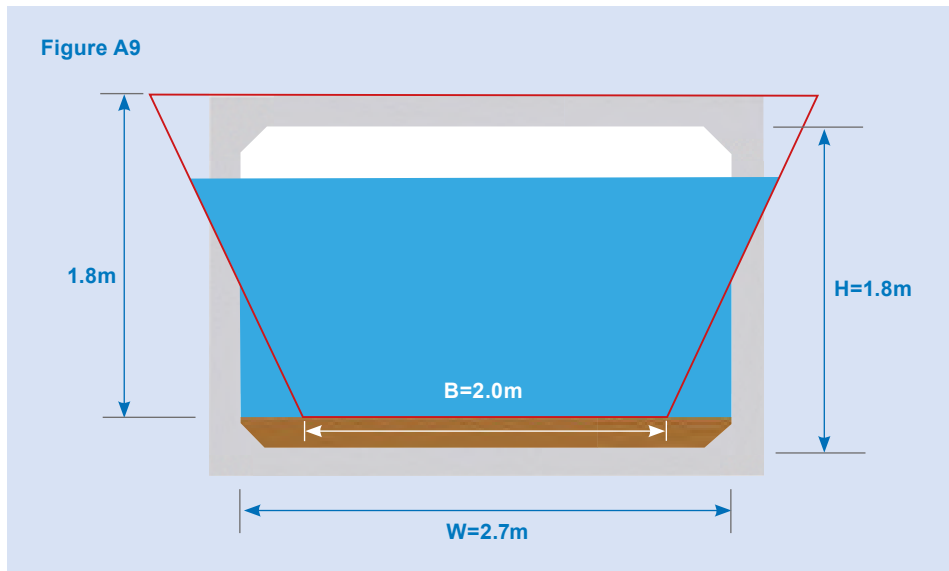

Training walls could be installed to improve the transitions. Benching would increase flow depth and velocity at low flows.

Other hydraulic design considerations

After determining the required size of a culvert, there will be other design factors and checks to consider to ensure that the culvert will perform satisfactorily.

Typical initial assessments include calculations relating to maximum permissible headwater level and afflux.

Barrel velocity should also be checked such that sedimentation within the culvert is not a problem.

More detailed assessments would look into inlet and outlet control conditions, determining discharge capacity for a given headwater level and headwater level for a given discharge. The use of screens should be assessed for sizing and head loss.

1.4.3 Box Culvert Structural Design

The design of box culverts has always required reference and understanding of traffic loading on bridges, and this remains a fundamental requirement when undertaking a box culvert design. In addition to BS EN 1990, BS EN 1991 and BS EN 1992, and National Annex's, there is now a specific product standard, BS EN 14844+A2:2011 'Precast concrete Products – Box culverts', dealing with aspects of design, manufacture and installation. This document in turn, cross references BS EN 13369:2013 'Common rules for precast concrete products'. Additionally there is non-contradictory complementary information in the form of PD 6694+A1:2020. Recommendations for the design of structures subject to traffic loading to BS EN 1997- 1:2004 and PD 6687-2:2008 Recommendations for the design of structures to BS EN 1992- 2:2005.

BPDA member companies can design the culverts for the required traffic load models as part of the contract. Assistance can be given at enquiry stage on the design.

Generally, within the Eurocodes, the principles of reinforced concrete design for Ultimate Limit State bending and shear are the same as for designs to British Standards. There are small

differences in the allowable shear stresses but this does not significantly affect the design of box culvert units. However, the loadings now required by the BS EN 1991-2 are significantly greater than former British Standards. This results in the need to provide a structure with increased structural capacity.

1.4.4 Relevant Standards

There are documents which need to be consulted to achieve an appropriate and compliant design for a box culvert. It is essential that the initial design parameters are clearly defined at an early stage, to ensure the Client is provided with a product which meets their requirements.

Table A8. Standards used in the design of box culverts

Standard	How the standard is used
<p>BS EN 1991-2:2003 Eurocode 1:Actions on Structures - Part 2: Traffic Loads on Bridges</p>	<p>This document sets out the loading classes for road bridges and defines a series of Load Models (LM1-LM3),</p> <ul style="list-style-type: none"> • Load Model 1 - Concentrated and Distributed Load • Load Model 2 - Single axle loads • Load Model 3 - Loads for Special vehicles which includes types SV80, SV100 and SV196 • Load Model 4 - Crowd Loading (this load model is not used as the UDL value is less than the base UDL used in LM1) <p>Each Load Model describes a configuration of wheel loading to represent different wheeled vehicles. It is significant that the wheel loads within these models is now 150kN (LM1) and 200kN (LM2) & 165kN (LM3). This is compared to the previous wheel load of 30HB at 75kN.</p> <p>The design is progressed, generally adopting the worst case effects of these Load Models. The loads are applied to the culvert structure by considering the zones of influence as described in PD 6694 (Fig 11). PD 6694 (Table 7), also defines the horizontal surcharge pressures to be applied to the structure.</p> <p>Horizontal loads in terms of braking and acceleration forces are defined within the Eurocode, and these are applied in conjunction with the relevant vertical loads.</p>
<p>BS EN 1992-1-1:2004+A1:2014 – Eurocode 2:Design of concrete structures - Part 1-1: General rules and rules for buildings</p>	<p>Having established the appropriate applied loads, and from an analysis to determine the resultant bending moments and shear forces, the detailed concrete design is undertaken, in accordance with this document.</p>
<p>BS 8500-1:2015+A2:2019– Concrete - Complementary</p>	<p>The performance of the culvert structure and its defined working life will be determined by defining a suitable concrete specification, and by adopting suitable cover to the reinforcement.</p>
<p>British Standard to BS EN 206-1, Part 1: method of specifying and guidance for the specifier</p>	<p>Section 4 of BS EN 1992-1 covers durability and cover requirements. The Exposure Classes are as EN 206-1, but in the UK BS BS8500-1 is adopted, to define a suitable concrete specification, taking account of corrosion due to carbonation (XC), chlorides (XD), sea water (XS), & freeze/thaw (XF). Generally, XD2 is adopted for buried highway structures more than 1.0m below an adjacent carriageway and XD3 for buried highway structures less than 1.0m below the carriageway level. For a structure that is not buried adjacent to a carriageway XD1 is adopted. The required concrete specification for XD3 is described by it's a strength class C40/50 with an associated minimum cement content of 380kg/m³ and maximum water cement ratio of 0.35 when cement types IIB-V or IIIA are used. In some circumstance a client may request that the internal surface and external face are designed with different exposure classes.</p>

Table A8 (Continued)

Standard	How the standard is used
	<p>For particular cases of exposure (high sulphate conditions), it may be necessary to refer to the BRE Special Digest 1:2005 - Concrete in aggressive ground, which gives guidance on concrete specification and additional protective measures.</p> <p>Intended working life is generally specified at 100 years. However, the clause 1704 of Series 1700 accepts that concrete complying with the 100 years requirement of BS8500 will provide a working life of 120 years. In addition NA.2.1.1 EN 1990 recognises that a design working life category 5 will have a working life of 120 years.</p> <p>Precast concrete generally adopts a higher concrete specification, when compared to in-situ concrete; this is mainly due to the addition of increase amounts of cement to achieve faster curing times. This allows the adoption of lower cover to the reinforcement, and when considered in conjunction with a smaller Δc value, (allowance for rebar deviation due to tighter QC controls), will result in a more economic design.</p>
BS EN 13369:2013 - Common rules for precast concrete products	This standard is a generic document, which sets out requirements to the range of products which are produced in a factory environment. It is intended to act as a reference document which provides guidance on the various issues associated with precast concrete elements and their manufacturing, (e.g. durability, tolerances material requirements, testing). It is intended to provide a more consistent approach to standardisation in the field of precast concrete products. General references to more specific Eurocodes are included.
BS EN 14844:2006 - Precast concrete products - Box	In a similar manner to BS EN 13369, the standard provides guidance on materials, testing, and geometry etc., and production requirements, together with reference to design criteria, although this is generally in the form of cross references to the standards mentioned previously. This is a 'harmonized' standard and fully encompasses the requirements of the EC. Consequently this standard leads to the CE/UKCA marking now required on box culverts

Traffic Loads on Highway Structures

Prior to March 2010 the design of box culverts was to BS5400 / BCA specification / BS8110 as noted in table E1. Since March 2010 these have been superseded and box culverts are designed to Eurocodes.

Table E2 shows the traffic load options to be used in the design of box culverts and compares the design criteria prior to the introduction of the Eurocodes. In addition the load reduction factor ' α ' is introduced which recognises where the applied load can be reduced on non-major roads.

Table A9

Road Category (HA Interim advice Note 124/11)	Prior to March 2010	Eurocode loading	Traction and braking	α
Motorways / Trunk Roads/ Principal Roads	HA / 45 Units HB <i>BS 5400-2</i>	LM1-3 <i>BS EN 1991-2</i>	Yes	1.0
Other Public Roads / Principal Roads	HA / 45 Units HB <i>BS 5400-2</i>	LM1-3 <i>BS EN 1991-2</i>	Yes	0.8
Light traffic / Field loading (3T-16T vehicle)	Field Loading <i>BCA Specification</i>	Category G 120kN axle load (2 x 60kN wheels) <i>BS EN 1991-1</i>	No	*

*A value of 0.4 in combination with LM1 can be considered equivalent

Figure A10. Load Model 1 (LM1)

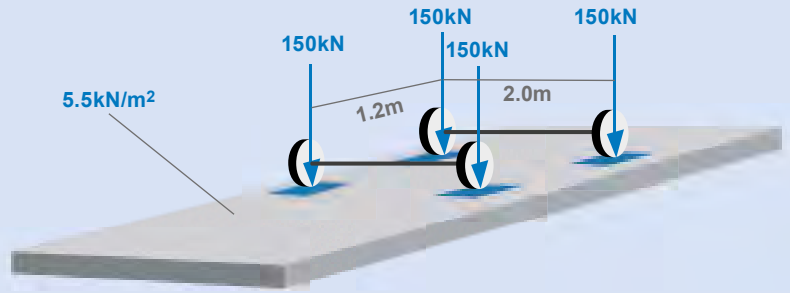

Notes:

LM3 should be determined for the individual project in accordance with BS EN 1991-2 and NA 2.16. However it is generally not critical on short spans up to 5m.

Values of α correspond to classes of road traffic. For common applications EN 1991-2 Cl 4.3.1 Note 2 permits a moderate reduction of α factors (10-20%)

Culverts can be designed for other traffic loading categories which are to be agreed with the scheme designer.

'General Effects' are considered for flexure and shear, i.e. stability checks are not undertaken.

Any plant equipment that is required to traffic over the culvert must be designed for as it may exert a higher loading than the normal traffic load exerted in the installed state.

Application of Load Model 1 for General Verifications Cl 4.3.2(1) (a)

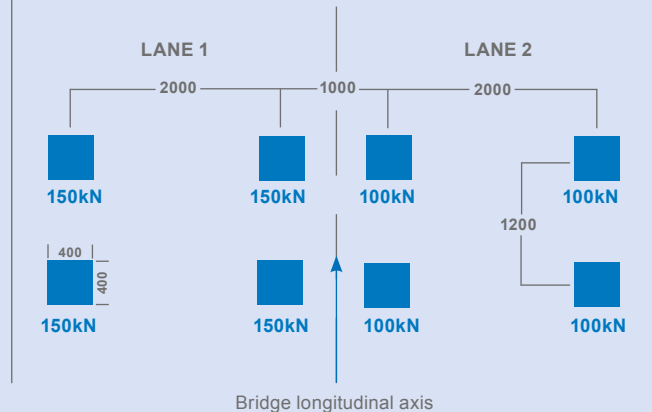

Axle loads to be applied in conjunction with a UDL as a Table 4.2 BS EN 1991-2:2003

Figure A11. Load Model 2 (LM2)

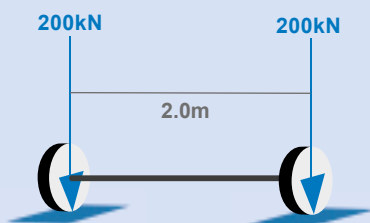

Application of Load Model 2 (applied any location on carriage way)

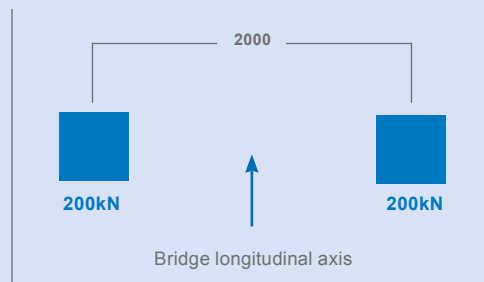
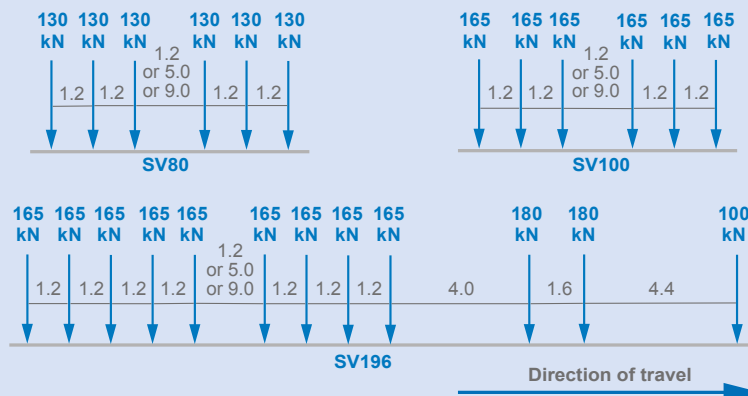
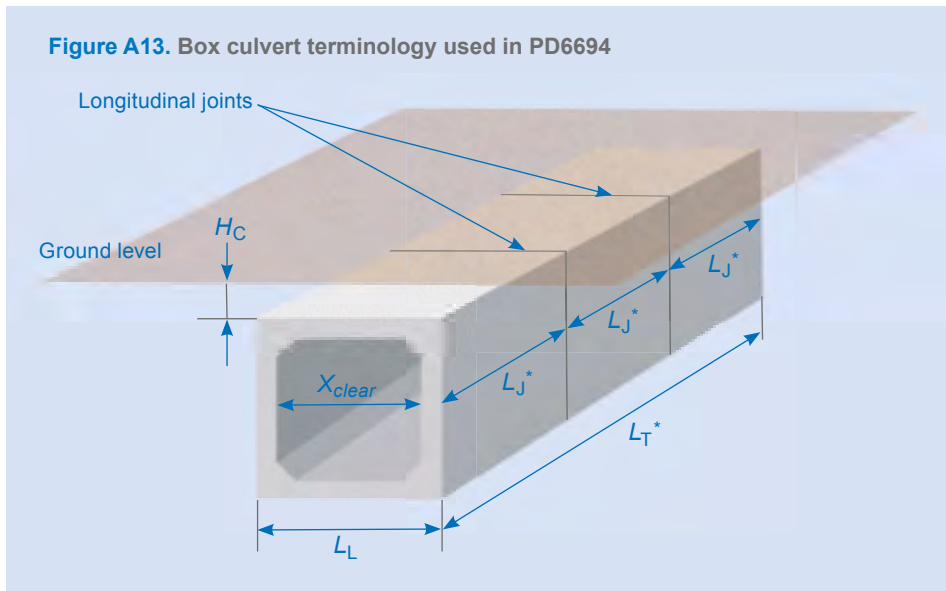

Figure A12. Load Model 3 (LM3)



Early Age Thermal Cracking

Early thermal cracking need not be considered for precast segmental construction where the segments are monolithic and of 3m length (L_j) or less. Additionally it is not applicable to precast concrete box culvert sections that are cast monolithically under strict quality controlled factory conditions in unrestrained moulds.



Fatigue

Fatigue verification for road bridges (culverts considered as similar structures) is not necessary where:

- The clear span to overall depth ratio of the slab does not exceed 18
- Buried arch and frame structures have a cover depth of 1.00m for road and 1.50m for railway bridges Ref: BS EN 1992-2 Table NA.1 cl 6.8.1

For example see figure E6 which has a ratio of $3000 / 225 = 13.3 < 18$ OK

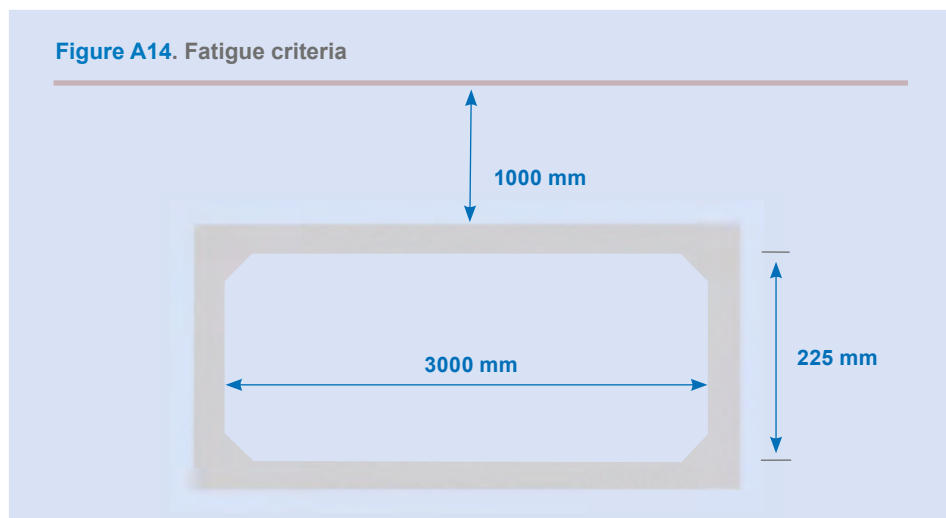

Stability

Considerations regarding overturning and sliding are not considered by BPDA members. This is the responsibility of the overall scheme designer.

2 - INSTALLATION: PIPES

This section describes the recommended procedure for the installation of concrete pipelines in trenches for non-pressure (gravity) applications or when occasional periods of hydraulic surcharge may occur. It covers the types of laying conditions most commonly encountered in practice. In situations beyond these general conditions, the pipeline designer and the site engineer should give suitable instructions to supplement this guidance.

Pipelines laid under embankments require special consideration whilst those installed by pipe jacking require the use of specialised techniques.

2.1 Planning

General

Prior to constructing the pipeline, the contractor will need to organise the work from the contract documents, specification, drawings and bill of quantities.

The line and level of the sewer, any side connections and the positions of the manholes will have been determined at the design stage but some flexibility in construction should be permitted to cater for circumstances such as foundations or buried services not shown on the drawings. An agreed re-siting of a manhole may save time and additional expense.

Sequence of operations

- a) Plan and set out the work including location of manholes.
- b) Receive, check against specification and store deliveries of materials on site.
- c) Excavate trench and install trench support system.
- d) Lay bedding material forming socket holes as appropriate.
- e) Check for damage, lay and joint pipes, air testing every third or fourth pipe as laying proceeds. Check line and level.
- f) Place and compact sidefills with bedding or selected materials.
- g) Continue placing and compacting sidefills withdrawing trench sheeting in stages.
- h) Place initial backfill above pipe continuing withdrawal of sheeting.
- i) Air and/or water test or inspect visually prior to final backfill.
- j) Complete backfill, compacting as appropriate.
- k) Final acceptance, air and/or water test or inspection.
- l) Reinstatement of surface as appropriate

2.2 Handling and storage

Lifting equipment

Time and place of off-loading should be agreed before units arrive on site. The contractor should have suitable equipment for off-loading, stacking and stringing out pipes and other units on site.

All lifting tackle must be of good sound construction and should be regularly tested and certificated.

Off-loading

Whenever possible, pipes and other units should be off-loaded in the reverse order that they were loaded. The vehicle must not be moved if any part of the load is unsecured. Off-loading

should take place at the nearest hard standing to the point of installation; all units must be left in a stable position well clear of the edge of the trench.

For further information, refer to the BPDA Health & Safety Off-loading Guide

<http://www.precastdrainage.co.uk/page/pipe-laying-lifting>

BPDA member companies are also available to advise on general handling of products and appropriate lifting equipment. Member companies contact details can be found here:

<http://www.precastdrainage.co.uk/suppliers>

Use of tackle

Where provided, lifting holes, anchors etc. must be used with the correct equipment to lift the units (note - installed lifting points may not necessarily be suitable for the transportation of a product across a site).

Pipes

Pipes should be handled individually using a properly designed “C” hook, beam sling or other purpose-designed system. Small diameter pipes may be slung through the bore providing the sling is sleeved and protected around the joint. This is important in order to avoid damage to jointing surfaces and consequent leakage of the laid pipe. ‘Pipe hooks’ must not be used. Slings may be made of cordage, canvas, or man-made fibres, but not chains.

Many manufacturers offer a combined lifting and jointing system using a three-legged chain and cast-in facilities (larger pipe sizes only). A special concrete pipe lifter is also available providing improved site safety, reduced installation time, labour and cost savings. Further details relating to the concrete pipe lifter and other proprietary lifting devices can be found in the BPDA Site Guide, available at www.precastdrainage.co.uk and directly from BPDA members.

The Concrete Pipe Lifter is designed to improve site safety and increase efficiency during the lifting and installation of precast concrete pipes. It is connected to an excavator via a quick hitch attachment. www.concretepipelifter.co.uk



How to Use

- Perform appropriate pre-work checks to ensure all equipment is working properly and has valid operating certificates, where required.
- Connect Pipe Lifter to excavator via quick hitch coupling, ensuring correctly attached and locked in position.
- Fully insert the long lifting arm horizontally into the barrel of the pipe and carefully raise to make contact with the internal crown. When installing pipes, ensure it is lifted from the socket end.
- The clamp arm will slowly press down onto the top of the pipe and hold it in position.
- The pipe may now be lifted and transferred to a suitable storage location or placed into the prepared trench and jointed following the application of an approved joint lubricant to the pipe

spigot. Care should be taken to avoid lubricant coming into contact with the lifting area as this can cause the pipe to slip.

- Depending on the weight of pipe, depth of installation and lifting capacity of site plant, the pipe may be tilted up to 30 degrees from horizontal and maneuvered between struts on trench support systems. It can also be used to push the pipe home to ensure formation of the correct joint gap.
- Check limits of use before operation including lifting capacity and the compatibility of trench support system with the Pipe Lifter to ensure that struts do not interfere with the removal of the lifter from the pipe.
- When installing a pipe, no personnel should be in the working area or come into contact with the Pipe Lifter, excavator or any pipe in transit.

Other units

Where lifting eyes or lifting holes are provided they should be used. Extra care should be taken when lifting bends and junctions (pipes with inlet).

Chocks

When pipes are loaded, transported or stacked, sufficient timber chocks should be provided. Chocks or packing between individual units should not be removed until lifting tackle is secured.

Care in handling

Pipes and other units must never be dropped. Pipes which have to be moved should be lifted and never dragged. When pipes have to be rolled, beware of rocks or boulders. Care should be taken to avoid damage especially to jointing profiles.

Stacking on site

Ideally, pipes should be strung out and secured beside the trench where they are to be used. Where stacking is necessary this should be on level ground and the bottom layer of pipes securely chocked to prevent the stack from collapsing. Pipes should be supported under the barrel so that the socket is free of load and so that the jointing faces are not damaged. They should be stacked barrel to barrel with sockets overhanging, or with spigots protruding as preferred.

Fig. B1. Typical stacking arrangement

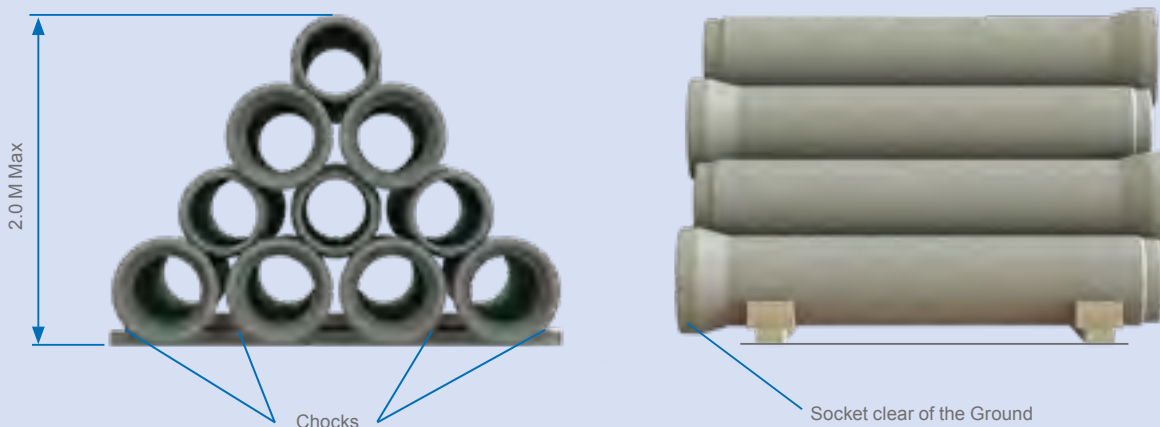

For safety reasons and to prevent damage to the lower layers of pipes in the stack, pipes should not be loaded or stacked in a greater number of layers than shown in Table B1 overleaf.

Table B1. Pipe stacking layers

Nominal size (DN)	Number of layers
150-225	6
300-375	4
450-600	3
675-900	2
above 900	1

Storage of loose jointing materials

Precast concrete pipes are normally supplied with an elastomeric sealing gasket integrally-cast into the socket of the pipe. For other forms of joint seal, the quantity, type and diameter of jointing rings or other jointing materials should be checked with the delivery note at the time of off-loading. Elastomeric rings should be carefully stored and protected from sunlight, oils, greases and heat. If the rings have been tied they should be separated a few days before use in order to eliminate minor impressions which the ties may have caused. Rings should not be stored hanging from a hook.

2.3 Excavation and laying**Trench excavation**

The trench should be dug to the line, gradient and width indicated on the drawings or in the specification or as agreed with the Engineer. The safety of the public and site personnel is of paramount importance.

Trench width

Any increase in trench width above that specified could increase the load on the pipe and increase the quantity of the excavation and of bedding material.

A trench narrower than that specified may impede the proper placing and compaction of the bedding material and restrict working conditions in the trench during pipe laying.

A trench adjacent to a manhole may need to be wider but this should be taken into account at the design stage.

The trench width should allow for safe working alongside the pipeline. For recommended trench widths see load tables A3 & A4, pages 29 & 30.

Formation

Uniform support along the pipeline is essential.

Rock outcrops and soft zones such as peat or boggy material which can cause differential settlement should be dug out and replaced with well tamped selected material.

Ground water should be kept below the bottom of the trench during pipe laying operations by the use of temporary drains, sumps or a designed well-point system. The water level should not be allowed to rise before backfilling is completed.

If the trench bottom is likely to be disturbed by trampling during pipe laying, selected material should be placed to protect it.

Where the trench bottom is unstable, for example in marshy ground or running sands, special measures are necessary to ensure proper embedment.

A trench excavated in clay should not be kept open any longer than necessary to avoid instability due to change in moisture content.

Pipe laying

Before lowering into the trench, each unit should be inspected carefully for any damage which may have occurred in transit or during handling and storage on site. Pay special attention to jointing surfaces. Units should be lowered carefully into the trench with tackle suitable for their weight and for the depth of the trench.

The contractor should have available, at the required time, all material and equipment necessary for carrying out the work in accordance with the specification and statutory safety requirements.

The contractor must ensure that the size and strength class of pipes or other units conform to the contract specifications and manufacturer's recommendations. In the case of integrated seals, the joint must be prepared i.e. the application of the correct lubricant and the removal of the seal positioning strip (where present).

Normal gradients

Pipes should be supported by the bedding over the length of their barrels and their weight must never be carried by the sockets or by bricks and rocks in the trench bottom. Bedding under the pipe should be scooped out to accommodate pipe sockets at each joint. The pipes should be laid and assembled in correct alignment.

If, in order to curve the pipeline it is necessary to deflect the pipes at the joints, the deflection should be applied only after the joint has been made in the normal manner and should be limited to 75% of the manufacturer's recommended limits to allow for any subsequent movement.

Mechanical plant must not be used to press pipes down to their correct level.

Changing direction

Change in direction, either horizontal or vertical, should be made at a manhole or by means of a precast bend unit.

Passing through rigid structures

For a pipeline connection to a manhole or passing through a wall it is essential that the pipeline joint retains its flexibility. This may be achieved by casting a short length of pipe into the wall of the structure and providing a flexible joint adjacent to the wall. Depending on ground conditions, short length pipes (rockers) should be used (see Section 1.3.6).

Unstable ground

In unstable ground an appropriate installation method should be determined. The following possibilities should be taken into account:

- Use of short lengths of pipe.
- Use of continuous support on pile caps/beams.
- Special preparation of trench bottom.
- Trenchless methods of construction such as pipe jacking or heading.

Passing under highways or railways

If disruption of traffic is to be avoided, pipes should be installed by jacking or in heading.

2.4 Jointing

A number of different joint designs are manufactured, all of which comply with the performance requirements of BS EN 1916 and BS 5911-1.

The pipe manufacturer's jointing instructions should be complied with but the basic requirements for jointing concrete pipes are:

- Pipes should always be handled in a way to avoid damage, especially the spigot and socket ends and joint surfaces.
- Prior to jointing, the socket and spigot should be cleaned and inspected to ensure they are in good condition.
- Most standard concrete pipes are supplied with an elastomeric seal integrally cast into the socket of the pipe

For Integrated Seal Joints

- Remove the protective polystyrene strip (where present) by using the tape provided. Grip the tab of the tape and pull firmly towards the centre of the pipe. Residual polystyrene in the rear corner of the socket is acceptable but the area behind the seal must be clear.
- Lubricant should be applied to the spigot end of the pipe, ensuring the radius area and entire length of the spigot is covered. Additional lubrication may be also applied to the seal face to assist jointing.
- Only use lubricant as recommended/supplied by the manufacturer.
- Enter the spigot carefully into the socket, ensuring that the pipes are correctly aligned.
- Always follow the manufacturer's instructions.

For Spigot Seal Joints (Rolling and Sliding Seals)

- Stretch and position the seal onto the spigot of the pipe ensuring it is not twisted. Even out the stretch by lifting and releasing at several points around the spigot.
- The seal should be located on the spigot in accordance with the manufacturer's instructions.
- Rolling seal joints do not require lubrication. Most sliding seal are internally pre-lubricated and do not require additional lubrication. If the joint design does require lubrication then follow the manufacturer's instructions.
- With rolling ring joints, offer up the pipe spigot to the socket, but keep clear of engagement by 25mm so that the joint ring is not disturbed. With sliding ring joints, the joint ring should be just in contact with the socket.
- Enter the spigot carefully into the socket, ensuring that the gasket is correctly positioned and that the pipes are correctly aligned.
- Always follow the manufacturer's instructions.
- Jointing tackle or chain systems should be used in accordance with the pipe manufacturer's instructions.
- Fully support the pipe so that it does not exert undue weight on the seal whilst closing the joint to the recommended joint gap.
- Joint the pipes in accordance with the manufacturer's recommendations, making sure that the pipe moves without excessive slew or misalignment, that extraneous matter does not enter the joint and that the joint is not damaged and correctly positioned. For jointing bends, special procedures may be appropriate.

- After adjusting for line and level, release the tackle. Care should be taken not to disturb the pipe or bedding material when removing slings.
- The finished internal pipe joint gaps should be within the tolerances as specified by the manufacturer.
- It is advisable to carry out an air test on the installed pipeline after the laying of at least every 3-4 pipes to ensure satisfactory installation has been achieved.

Back laying

In special circumstances, such as at manhole connections, it may be necessary to joint a pipe socket onto the spigot of a pipe already laid.

When this is done, additional care is necessary to ensure that the joint is properly made with the joint ring correctly positioned and that bedding material is not scooped into the joint.

Fig. B2. Integral sealing ring - standard for most UK concrete pipes



Fig. B3. Pre-lubricated Sliding Ring



Fig. B4. Rolling Ring – circular / tear drop / 'G' ring



NOTES:

1. Each joint type is diagrammatic and typical.
2. Rolling and fixed rings may be one of a variety of different profiles / cross sections / designs.
3. Tolerances of joint profiles shall be determined by the pipe manufacturer and described in factory documents.
4. Joint assembly shall be watertight / airtight when constructed in strict accordance with the manufacturer's recommendations.
5. Pipes with integral seals offer some protection to the seal, however the same precautions should still apply to protect the seal.

2.5 Reinstatement

Trench reinstatement

After inspection and testing, backfilling should proceed whilst withdrawing trench sheeting in stages where practicable.

The sidefill is of great importance and close attention to its selection, placing and compaction will protect a new pipeline.

Good trenching practice including controlled removal of temporary supports and compaction of backfilling as described above not only protects the pipeline but will also reduce settlement and the risk of damage to adjacent underground services or structures.

The trench should be backfilled as soon as possible after the pipes are laid bearing in mind any specified test and inspection requirements. Compaction of the envelope of material immediately around the pipe is extremely important. In trench installations, as space is limited, mechanical compactors are commonly used but caution should be exercised so as not to damage or displace the pipe. The material should be compacted at near optimum moisture content and should be brought up evenly in layers on both sides of the pipe, withdrawing trench sheeting as backfill proceeds. Backfill material should not be pushed into the trench from the surface nor dropped in bulk directly onto the pipe.

Heavy mechanical equipment should not be allowed to traverse pipelines with limited cover except at prepared crossing places.

Fill material

Material for sidefill, initial and final backfill should be similar in character to the surrounding soil; for example, the use of single size granular material in clay soil will create a natural drainage channel that could cause subsequent settlement.

Sidefill and initial backfill should be free from large stones, heavy lumps of clay, frozen soil, tree roots and other rubbish, and should be readily compactable.

Sidefill

The sidefill should be placed and compacted as soon as possible after laying, or as soon as it is safe to do so without damaging concrete beddings. Compaction should be carried out evenly on each side of the pipe to prevent lateral or vertical displacement.

Initial backfill

This should also be placed as soon as possible in order to provide protective cover of not less than 300mm compacted depth. This should consist of bedding or selected material placed carefully and evenly over the top of the pipe and lightly compacted by hand.

Removal of trench supports

As backfilling proceeds, trench sheeting should be removed as soon as it is both safe and practicable to do so.

Remaining backfill

This should be placed evenly in layers and compacted as appropriate.

2.6 Testing

Acceptance tests on the completed pipeline give an indication of the level of control of workmanship and materials during construction.

Visual inspection

Check for: -

- | | |
|-----------------------------------|-------------------------------------|
| a) Obstructions and debris. | c) Joints properly sealed. |
| b) Structural soundness of pipes. | d) Line and level within tolerance. |

Man entry sized pipelines can be physically inspected whilst smaller diameters can be visually inspected from manholes or by means of CCTV cameras.

Air and water tests

All lengths of drain and sewer up to DN 1000 should be tested for leakage by means of air or water tests.

These tests should be carried out after laying and before backfilling. Some backfill may be placed at the centre of each pipe to prevent movement during testing. Short branch drains connected to a main sewer between manholes should be tested as one system with the main sewer. Long branches should be separately tested.

Air Test

The air test is more convenient than the water test, but the leakage rate cannot be measured accurately. An excessive drop in pressure in the air test may indicate a fault in the line such as a displaced sealing ring or it may be due to faults in the testing apparatus. Therefore, the first check must be on the apparatus, especially the seals of the stop ends and all connections.

The point of a leakage may be difficult to detect but spraying with soap solution could indicate such leakage by the presence of bubbles.

Failure to pass this test is not conclusive. When marginal failure does occur, a water test should be performed and the leakage rate determined before a decision on rejection is made.

Air test requirements are specified in 'Civil Engineering Specification for the Water Industry'.

It is strongly recommended that inflatable stoppers are used for air testing.

A successful test is achieved if the equipment shows a fall in pressure of no more than 25mm after 5 minutes, having allowed a suitable period for stabilisation.

If the pressure falls sharply and the pipes appear to have failed, check the test equipment is in good condition, that the stoppers are not leaking (use industrial soap around the edge of the stopper to provide an effective seal if necessary) and check the joint rings are correctly located or re-test after allowing temperature to settle.

A video on how to air test concrete pipelines is available at the BPDA channel in Youtube:
 Link: <https://www.youtube.com/watch?v=UdohjdbKP0o>



Water Test

A water test is the more conclusive method of testing a completed pipeline but problems of availability and disposal of the quantity of water involved may cause difficulty. Before backfilling, leakage can be clearly located, its amount assessed and where necessary, appropriate remedies applied.

To test the pipeline:

- a) Insert plugs in both ends of the drain or sewer and in connections if necessary. Precautions should be taken by strutting or otherwise, to prevent any movement of the drain or sewer during testing.
- b) Fill the system with water ensuring all the air has been expelled.
- c) Allow at least two hours before test readings are taken to permit conditions to stabilize, adding water to maintain test head.

It may be necessary to extend this period for large diameter pipes, up to twenty-four hours or more before a stable condition is reached.

- d) Apply required test head at the upper end by means of a flexible pipe leading from a graduated container or stand pipe.
- e) Apply the test pressure of 1.2m head of water above the soffit of the drain or sewer at the high end with a maximum of 6m head at the low end. If this exceeds 6m test the drain or sewer in stages.
- f) Measure the loss of water over a period of 30 minutes by adding and metering quantities of water at intervals of 5 minutes to maintain original water level in the standpipe.

Over this 30 minute period, the quantity of water added should not exceed 0.05 litre per 100 linear metres per millimetre of nominal size of the drain or sewer.

For example:

For a 150m length of DN 800 pipe the allowable leakage would be:

$$0.05 \times \frac{150 \times 800}{100} = 60 \text{ litres}$$

Should the pipeline not comply with these requirements it will probably be attributable to one of the following:-

- a) Leakage from test equipment.
- b) Trapped air.
- c) Leakage from joints, e.g. displaced ring.
- d) Leakage from damaged or defective pipe.

2.7 Jetting

A jetting resistance of 12 MPa (120 bar) using a moving nozzle and/or 28 MPa (280 bar) using a stationary nozzle can be assumed acceptable for use on precast concrete drainage systems.

3: INSTALLATION - JACKING PIPES

3.1 Introduction

The installation of pipelines for drainage purposes has traditionally been carried out using open-cut trenches in both urban and rural locations. However, in recent years an increasing proportion of pipeline construction projects have utilized pipe jacking or the form of the miniaturized tunneling technique known as microtunneling.

The basic pipe jacking method has been used in various forms for centuries but only in the past decades have we seen significant advances in equipment and technology.

This has raised confidence in the technique and numerous successful pipeline engineering schemes have used pipe jacking and microtunneling.

Normally, for pipelines constructed in this manner up to DN 900 the technique is referred to as microtunneling and above this as pipe jacking, but the principle remains the same.

3.2 Technique and equipment

The pipe jacking or microtunneling method consists of the construction of a number of excavated shafts from which a tunneling shield is launched and behind which a succession of smooth-walled concrete pipes are jacked. When the shield reaches the destination or reception shaft, it is either re-launched in a different direction or removed to another location and the process repeated. The excavated drive and reception shafts are usually converted to finished manholes once pipeline installation is complete.

Spoil excavated by the rotating cutting head in the front of the shield is removed by an auger flight or by mixing with water and pumping to the ground surface for treatment and disposal. Some progress has been made with the development of machines which can compact soil to the sides of the shield as it advances. Other equipment types use vacuum systems for the removal of excavated material to the surface.

Particularly high levels of installation accuracy can be achieved with these systems since they use sophisticated steering and guidance methods based on laser technology and optional automatic computer control. Finished bores have frequently been described "like rifle barrels". Equipment has been developed which can install pipes in small diameters down to DN150 for house connections and lateral drains without the need for a trench.

3.3 Advantages

The advantage of using a trenchless method can be substantial. Any attempt to dig up long trenches within an urban area often results in severe disruption, delays and diversions to traffic, environmental pollution through noise, dust and dirt, loss of profit for local businesses, damage to properties or other buried pipes and cables and so on. These items are usually referred to as social costs and are nearly always absorbed by the community rather than paid as direct engineering costs.

However, when one considers further, other equally serious problems become apparent. Sometimes, the as-dug material excavated from the trench is not suitable for re-use as backfill. This waste spoil must be transported away from the area and disposed at a suitable landfill site. Such sites are becoming more difficult to find and the cost of using them is increasing. Also, new backfill material such as crushed stone has to be imported to the site and these operations usually involve heavy wagons inflicting damage to roads and using fuel which in turn produces more pollution. These environmental costs are compounded by the damage and visual impact to the countryside from landfill and quarrying sites.

Pipe jacking and microtunneling can dramatically reduce many of these social and environmental problems. The technique offers significant benefits in reduced excavation since they only require relatively small launch and reception shafts for the tunneling equipment. Streets and roadways can often be kept open to traffic with little hindrance or disruption. The environment in general benefits from a no-dig approach because far less transportation of trench reinstatement materials is required, normally limited to only the displaced spoil from the pipes and manholes.

Reduced levels of reinstatement lead to cost savings, as much of the cost of a pipeline scheme is in the excavation and subsequent reinstatement. Installation depths of up to 35m have successfully been achieved which would not have been possible with open cut methods.

3.4 Products

The UK concrete pipe manufacturing industry is playing a leading role in the advancement of trenchless techniques. Several BPDA member companies produce jacking and microtunnelling pipes in a range of sizes. These pipes are manufactured to produce accurate joint surfaces with square faces and a strong high density concrete with a smooth surface finish to assist in reducing jacking forces.

Jacking and microtunneling pipes are available in sizes from DN 450 up to DN 2500 and utilise elastomeric seals in a steel banded joint. These pipes are manufactured to comply with the requirements of European Standard EN 1916:2002 and the UK complementary standard BS 5911-1:2002. The external surface of the pipeline is smooth for easy insertion through the ground during installation. For steel banded joints, both mild and stainless steel are available. Jacking pipes can be supplied with grout holes and cast-in lifting sockets as required.

Other products for use with this trenchless method include caisson sections in sizes from DN 2000 to DN4000 complete with base sections fitted with cutting shoe. Also produced are lead pipes which are rebated to accommodate the tunneling shield and interjack pipes (leading and trailing pipes in pairs) for use with intermediate jacking stations.

3.5 Further information

More information on the pipe jacking and microtunnelling method can be found in the publications of the Pipe Jacking Association (PJA) <http://www.pipejacking.org/publications>.

The United Kingdom Society for Trenchless Technology (UKSTT) is another useful source of information on trenchless techniques including pipe jacking.

4: INSTALLATION - MANHOLES

Manholes may be installed using fresh concrete to construct the base, channels and benching in-situ or by using a precast base system where units are manufactured and delivered to site with predetermined positions for connecting pipework using flexible, watertight elastomeric joints.

4.1 Planning

Sequence of operations

- a) Place the bottom unit with either integral precast or in-situ concrete base.
- b) Erect the required number of standard components and seal the joints as appropriate in accordance with the design/chosen method of construction.
- c) Place a precast reinforced concrete cover slab on top.
- d) If required, place a corbel slab then add the appropriate number of adjusting units.
- e) Fit the access cover and frame.

4.2 Handling and storage

- 1) Chamber rings may be supplied with lifting holes for the use with specialist lifting pins and chain/sling sets. Alternatively they may have pins cast into them for use with universal head-links and chain/sling sets.
- 2) Cover, landing and reducing slabs are usually cast with anchors allowing the use of hook and chain/sling sets.

Note: Apparatus used for lifting, may not necessary be suitable for the transporting of products across a site.

Other lifting methods may be available or available to order – check with manufacture for full details.

All products should be lifted individually.

Chamber rings must not be lifted by attaching lifting equipment to steps.

Chamber rings should be stored 'chimney' fashion i.e. not on their side, or rolled.

Chamber rings and all types of slabs should be stacked on level and stable ground and on timbers wherever possible.

4.3 Construction

To ensure that the manhole structure is vertical, accurate levelling of the formation for the precast base unit or the in-situ concrete foundation is essential. The depths of precast manhole components are nominal and therefore subject to manufacturing tolerance; this, along with the formation of joints, should be considered during the setting out process.

Normal considerations should be taken into account when assessing the suitability of the formation. Units should be laid on a prepared level foundation of adequate bearing capacity

The manhole can be built of either;-

-15-20mm graded, 14mm or 20mm single-sized, suitably compacted aggregate to provide a level base with a minimum depth of 150mm, with an additional blinding layer of fine material where required to account for unevenness or any other environmental factors.

- 150mm deep GEN 1(C8/10) concrete. The base unit should be placed whilst concrete is wet so it can be set level. Where the concrete has already cured, a levelling screed with a minimum

depth of 15mm-50mm sand/cement will be required between the foundation and the unit to prevent point loading.

Note: Normally, a granular bedding is recommended where the safe ground bearing pressure >200kN/m². In poor or wet ground conditions a concrete pad is advised. The manufacturer of the manholes can advise where required.

Shaft and chamber sections with tongued and grooved joints should be installed with the socket / groove facing upwards, whereas units with ogee joints should have the spigot upwards. Precast cover slabs can be installed onto the shaft or chamber rings (with appropriate mastic, mortar or seal). Suitable cover and frame can then be bedded on adjusting units to achieve the finished level required.

Note that the distance from ground level to the first step in the manhole is usually specified as not to exceed 675mm (where units are fitted with step or ladder system)

Jointing to pipeline

To allow for differential settlement between manhole and pipeline, short “butt” pipes, either spigot or socket, should be built into the wall of manholes constructed with an in-situ concrete base and a flexible joint incorporated as close as possible to the outside of the manhole wall or concrete surround, if used.

Depending on ground conditions, short length pipes (rockers) then connect the butt pipes to the incoming pipe runs. Additional care must be taken to ensure that the joints are properly made.

4.4 Jointing

Precast manhole components are provided with joints formed within the wall section (see typical figures below) and are sealed with proprietary mastic seals, sand / cement mortar, or with elastomeric joints. Precast concrete manhole units, well jointed, provide an adequate seal under normal conditions. Any lifting holes will need to be sealed with sand / cement mortar or a proprietary non-shrink mortar.

Joint strips typically have a thickness of 12mm and are offered in one or two layers as demonstrated in the table below.

Fig. D1. Examples of Manhole Joints

a) Cover, Landing and reducing slab joints

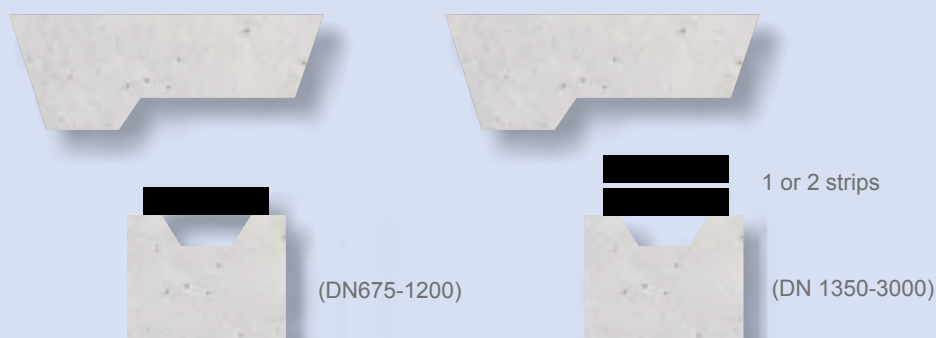
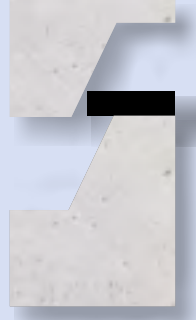

Fig. D1 cont. Examples of Manhole Joints**Reducing slab, shaft and chamber joint**

b) Tongue and groove



c) Ogee

**Other joints**

d) Landing platform joint

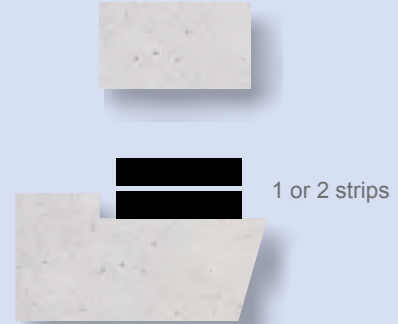
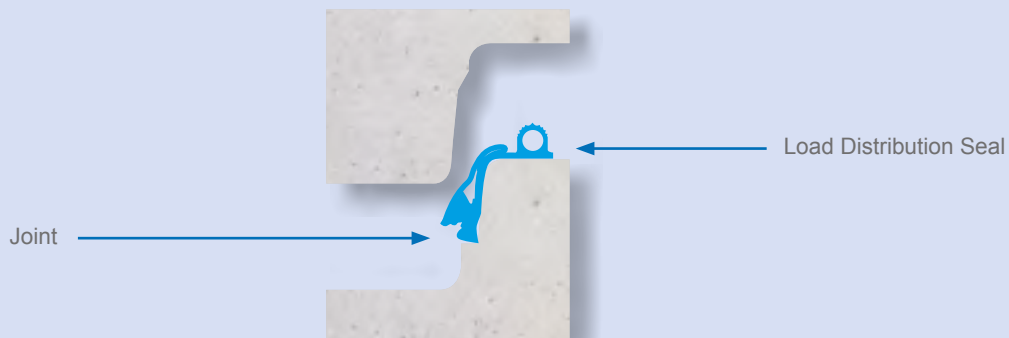
**Fig. D2. Example of Manhole Joint with Elastomeric Seal****4.5 Reinstatement****In-situ concrete surround**

In-situ concrete surround to precast concrete manholes, except for side-entry manholes, is unnecessary other than for exceptional structural reasons such as embankments, in sloping or unstable ground, where there is a large opening into the manhole, where it is a requirement due to a permanent head of water or where an individual specification requires it i.e. as in some types of adoptable manholes specified in Sewers For Adoption.

Note: Sewers For Adoption includes for the use of thicker walled (minimum 125mm thick) manhole rings without the requirement for a concrete surround.

Side entry manholes should be provided with a suitably designed GEN 3 concrete surround of at least 150mm thick extending the whole length of the pipe in which the manhole is placed.

Backfilling

As each precast manhole section is placed, backfill should be returned in layers and compacted as for pipelines. Backfill must be brought up evenly around the manhole to prevent displacement. Additionally, care should be taken to avoid damaging the connecting pipelines.

Special consideration should be given where construction plant is working in the vicinity of manholes. Where possible, traffic should be routed away from such structures and may require temporary protection with heavy steel plates or temporary additional cover material.

4.6 Testing

In working conditions manholes are not normally full of water. This only happens under rare conditions of surcharge. Prevention of infiltration is of more relevance than exfiltration and where this occurs, it can be remedied by sealing using an appropriate method.

Where testing of manholes is required, see Sewers For Adoption or Civil Engineering Specification for the Water Industry for suitable method.

5: INSTALLATION - BOX CULVERT

This section provides an overview for all parties engaged in the installation of box culverts. Where site conditions vary, for example, fluctuating ground conditions or vehicle loadings, supplementary instructions may be required. In this case more advice should be sought from the overall scheme engineer.

5.1 Planning

Prior to constructing the culvert run, the contractor will need to organise the work from the contract documents, specification, drawings and bill of quantities. The line and level of the culvert, any side connections and the position of any access openings will have been determined at the design stage.

Sequence of operations:

1. Plan and set out the working including the location of any incoming pipes and access openings
2. Prepare the ground ready to receive the delivery vehicle and act as temporary storage of the units if required
3. If using a crane undertake the required lift plan paying special attention to the ground conditions and that they are suitable for the crane
4. Arrival - Box Culverts arrive onto site in the pre-constructed / designated off-loading point
5. Inspection - items visually checked and identified / cross referenced from drawings
6. Offload - transport strapping released and culverts are off loaded, placing them in a holding location
7. Excavate the trench with a suitable angle of repose or install trench support system
8. Preparation the trench base by laying the granular bedding material (min 200mm thick) or pouring the concrete blinding (min 75mm thick) with 50mm deep granular overlay
9. Prepare the joint of the culvert in the holding area
10. Lift the units into place – checking the level
11. Pull the units together using a proprietary puller
12. Once installed and other connection are made (if any) back filling can commence

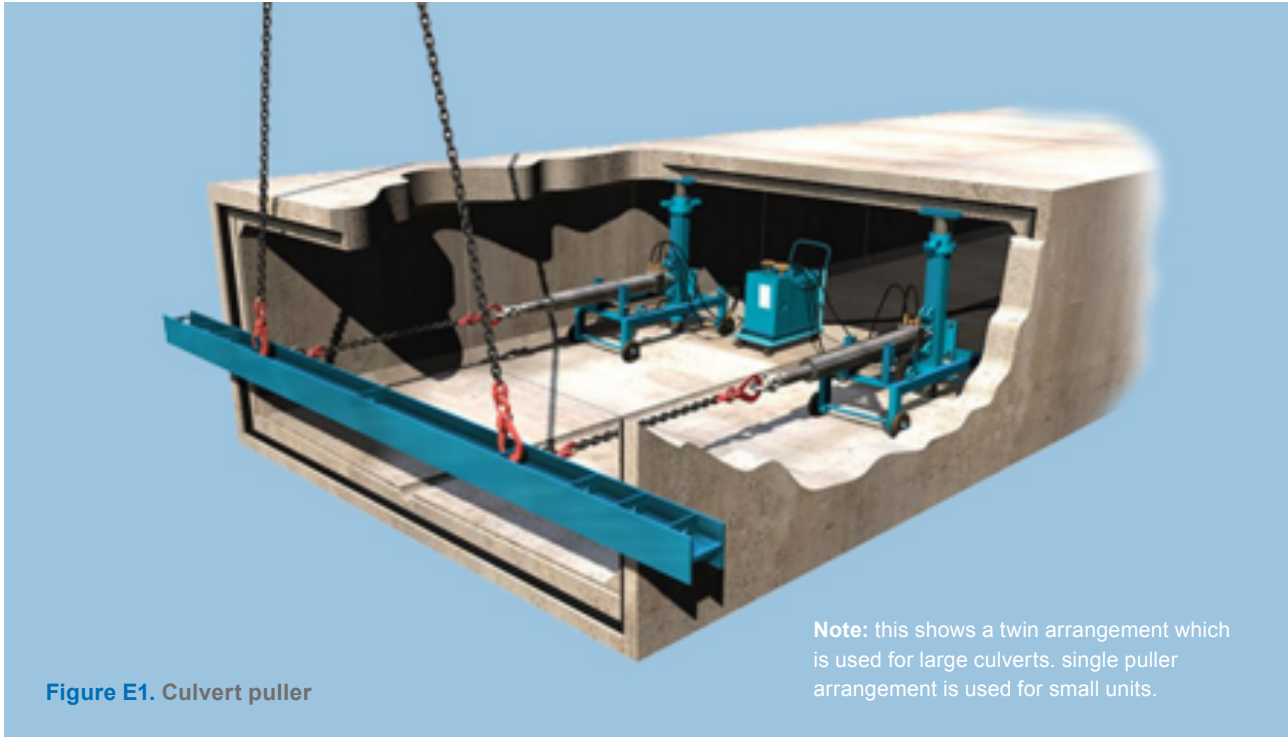

Figure E1. Culvert puller

Note: this shows a twin arrangement which is used for large culverts. single puller arrangement is used for small units.

5.2 Delivery, Handling and Storage

Prior to Delivery

Prior to taking the delivery on site there is a need to:

1. Agree with the BPDA member a delivery commencement date
2. Check item weights to ensure the correct lifting equipment is available

Taking Delivery:

- 1 On receipt of delivery ensure that the delivery note corresponds to goods ordered and that they are checked for quality.
- 2 The contractor is responsible for off-loading box culverts and should:
 - Provide suitable access and a hard standing which can be used safely by standard delivery vehicle
 - Provide a suitable crane and plant of adequate capacity to safely off-load and install the culvert units. Allowance should be made for tolerances and lifting tackle.
 - The load recipient should be aware that to be on the back of a lorry during the off-loading process constitutes “working at height” and as such, the requirements of the current Working at Height Regulations (2005) must be satisfied. It is the contractor’s responsibility to carry out a risk assessment of the operation and to provide all suitable measures to access the vehicle trailer safely with fall protection provisions provided, as deemed necessary
- 3 Lifting methods differ between box culvert manufacturers, Holes for eye-bolts, threaded lifting sockets or projecting loops are commonly used but other methods can be employed, The contractor should
 - Ascertain details of the lifting method used by the BPDA member
 - Provide all handling equipment necessary to operate a safe lifting method on site

- Ensure that any non-standard attachment to the lifting point is supplied and that full instruction are given for its use.
 - Under all risk assessments in addition to providing all handling equipment necessary to safely operate the lifting method on site
- 4 Where other methods, such as lifting forks, beams or slings are to be used, the contractor should:
- Consult the BPDA member to ensure that the proposed method is acceptable
 - Protect the box culvert and particularly the joining surfaces from damage while lifting
 - Ensure complete safety of operatives
- 5 Generally box culverts are transported as laid, but for safety reasons such as load stability or economy, the box culverts may be transported on end. The contractor should:
- Check with the BPDA member how the box culverts will be delivered
 - Where box culverts are delivered on end, establish a safe method of turning the units to the as laid orientation.
 - Provide any equipment necessary for the operation
- 6 The box culverts may be off-loaded into a storage area or they may be placed in line alongside the trench in which they are to be laid. In either situation:
- Before off-loading, visually inspect the units and check the identification label by cross referencing against the layout drawings
 - Lower them carefully on to a firm level base away from the edge of the trench
 - Box culvert units should be moved by lifting and never by dragging
 - In cold weather, protect open lifting sockets from freezing and bursting

5.3 Construction

Trench Preparation

Keeping to the specified line and gradient, the trench should be excavated ideally to a width equal to the box culvert width plus a minimum of 300mm to either side to allow for access to aid installation. However, specific site conditions regarding the excavation and ground stability will prevail. Reference should be made to BD31/01 section 5.0.

In certain circumstances with unstable ground, e.g. clay soils, it may be necessary to undertake additional works to provide stable ground conditions.

Bedding

Bedding is intended to level out any irregularities in the trench bottom and ensure uniform support under the full width and length of the box culvert.

1. Lay granular material over the full width of the trench to a minimum depth of 200mm having first removed any protective layer ensuring that it is sufficiently compacted.
2. Lay the bedding material only a minimum distance ahead of laying the box culverts.
3. Keep off the prepared base so far as practicable. Having achieved a flat, well prepared base, it should not be allowed to deteriorate.

As an alternative to granular bedding, a suitable concrete blinding slab can be used. Lay a flat apron of unreinforced lean-mix concrete, minimum 75mm thick in the prepared trench. On top of the blinding place a 50mm thick layer of granular bedding material.

Jointing

BPDA members employ different methods of joining the culverts together. Please refer to BPDA members for further information.

Reinstatement & Backfilling

Backfilling should commence as soon as possible after the box culverts have been laid.

- Fill the trench to the level of the top of the box culvert working evenly on each side
- Use appropriate backfill material well-compacted in layers not exceeding 200mm
- Do not use heavy vibratory equipment
- Continue filling over the box culvert and compact in layers
- Do not run heavy rollers or construction plant over the box culvert without protection

Care must be taken if the construction traffic passes over or close to the culvert and imposes loadings greater than those for which the box culvert has been designed for. In such cases protective measures will be required.

5.4. References

- BS EN 14844 - 2006 + A2:2011 - Precast Concrete product - Box culverts
- BS EN 13369:2013- Common rules for precast concrete products
- BS EN 1990:2002 Eurocode – basis of structural design (A new version will be published in November 2018)
- BS EN 1992-1-1:2004+A1:2014 – Eurocode 2:Design of concrete structures - Part 1-1: General rules and rules for buildings
- BS EN 1991-2:2003 Eurocode 1:Actions on Structures - Part 2: Traffic Loads on Bridges
- BS EN 1992-2:2005 - Eurocode 2 – Design of concrete structures –Part 2: Concrete bridges – Design and detailing rules
- PD 6687-2:2008 Recommendations for the design of structures to BS EN 1992-2:2005
- BD31/01 The design of buried concrete box and portal frame structures Design Manual for Roads and Bridges: Volume 2, Section 2, Part 12 (2001)
- CIRIA C689 Culvert design and operation guide (2010)
- PD6694-1 2011+A1:2020: Recommendations for the design of structures subject to traffic loading to BS EN 1997-1:2004
- BS 8500-1:2015+A2:2019 – Concrete - Complementary British Standard to BS EN 206-1, Part 1: method of specifying and guidance for the specifier

6: REFERENCES AND FURTHER READING

6.1 British Standards			
1	BS EN 197-1:2011 Cement. Composition, specifications and conformity criteria for common cements.	2011	BSI
2	BS EN 206+A1:2016 Concrete. Specification, performance, production and conformity.	2013	BSI
3	BS EN 450 (various parts) Fly ash for concrete.	2005-2015	BSI
4	BS EN 681-1:1996 – Elastomeric seals. Material requirements for pipe joint seals used in water and drainage applications. Vulcanised rubber.	1996	BSI
5	BS EN 752:2008 Drain and sewer systems outside buildings.	2008	BSI
6	BS EN 1295-1 Structural design of buried pipelines under various conditions of loading – Part 1: General requirements.	2019	BSI
7	BS 1881 (various parts) Testing Concrete.	1983-2015	BSI
8	BS EN 1916 – Concrete pipes and fittings, unreinforced, steel fibre and reinforced.	2002	BSI
9	BS EN 1917 – concrete manholes and inspection chambers, unreinforced, steel fibre and reinforced.	2002	BSI
10	BS 4449: 2005+A3:2016 Steel for the reinforcement of concrete. Weldable reinforcing steel, Bar, coil and decoiled product. Specification.	2016	BSI
11	BS 4482:2005 Steel wire for the reinforcement of concrete products. Specification.	2005	BSI
12	BS 4483:2005 Steel fabric for the reinforcement of concrete. Specification.	2005	BSI
13	BS 5911 – 1 : 2002 + A2 : 2010 - Specification for unreinforced and reinforced pipes	2002	BSI
14	BS 5911 – 3 : 2010 + A1:2014 - Specification for unreinforced and reinforced manholes and soakaways.	2010	BSI
15	BS 5911 – 4 : 2002 +A2 : 2010 - Specification for unreinforced and reinforced inspection chambers.	2010	BSI
16	BS 5911 – 6 : 2004 + A1 : 2010 - Specification for road gully and gully cover slabs.	2010	BSI
17	BS 6031:2009 Code of Practice for earthworks.	2009	BSI
18	BS 8500-1: 2015+A2 Concrete. Complementary British Standard to BS EN 206. Method of specifying and guidance for the specifier.	2019	BSI
19	BS 8500-2: 2015+A2 Concrete. Complementary British Standard to BS EN 206. Specification for constituent materials and concrete.	2019	BSI
20	BS EN ISO 9001:2015 - Quality management systems: Requirements.	2015	BSI
21	BS 9295:2020 Guide to the structural design of buried pipelines.	2020	BSI
22	BS EN 13101:2002 Steps for underground man entry chambers. Requirements, marking, testing and evaluation of conformity.	2002	BSI
<ul style="list-style-type: none"> - BS EN 16933-2:2017 Drain and sewer systems outside buildings — Design. Part 2: — Hydraulic design - Also see SuDS references on page 16 			

6.2 Industry References

1	Design and Construction Guidance for foul and surface water sewers offered for adoption - v2.0	March 2020	Water UK
2	Sewers for Adoption 6th and 7th Editions	March 2006 & August 2012	Water UK / WRc
3	Sewers for Adoption 6th Edition – Combined Addendum	March 2006	Water UK / WRc
4	Civil Engineering Specification for the Water Industry (CESWI) 7th edition	March 2011	WRc
5	Simplified Tables of External Loads on Buried Pipelines	1986	TRL HMSO
6	Guide to Design-Loadings for Buried Pipelines (Out of print)	1983	TRL HMSO
7	Tables for the Hydraulic Design of Pipes, Sewers and Channels 8th edition	2005	HR Wallingford and D H Barr
8	Specification for Highway Works	2001	Department of Transport HMSO
9	An introduction to pipe jacking and microtunnelling design	1995	Pipe Jacking Association PJA
10	Guide to Best Practice for the Installation of Pipe Jacks and Microtunnels	1995	Pipe Jacking Association (PJA)
11	Concrete in Aggressive Ground - BRE Special Digest 1	2005	BRE
12	Imported Granular and Selected As-dug Bedding and Side Fill Materials for Buried Pipelines Water Industry Specification 4-08-01	1994	WRc
13	Precast Concrete Pipes - Unreinforced and Reinforced, with Flexible Joints - Water Industry Specification 4-12-01	1991	WRc
14	Specification for Polypropylene Encapsulated Steps for Use in Manholes and Access Chambers - Water Industry Specification 4-33-01	1990	WRc
15	Specification for Flexible Couplings for Gravity Sewage and Drainage Pipes - Water Industry Specification 4-41-01	1993	WRc

6.3 Relevant Organisations	
<p>British Precast The Old Rectory Main Street Glenfield LE3 8DG</p>	<ul style="list-style-type: none"> • Telephone: +44 (0) 116 232 5170 • Fax: +44 (0)116 232 5197 • info@britishprecast.org • www.britishprecast.org
<p>British Water Vox Studios Unit V03 1-45 1 Durham Street London SE11 5JH</p>	<ul style="list-style-type: none"> • Telephone: 02035670950 • info@britishwater.co.uk • www.britishwater.co.uk
<p>BRE Building Research Establishment Garston, Watford WD25 9XX</p>	<ul style="list-style-type: none"> • Telephone: +44 (0)1923 664000 • Fax: +44 (0)1923 664010 • enquiries@bre.co.uk • www.bre.co.uk
<p>BSI British Standards Institution 389 Chiswick High Road London W4 4AL</p>	<ul style="list-style-type: none"> • Telephone: +44 (0)20 8996 9000 • Fax: +44 (0)20 8996 7001 • cservices@bsi-global.com • www.bsi-global.com
<p>CIRIA Griffin Court 15 Long Lane London EC1A 9PN</p>	<ul style="list-style-type: none"> • Telephone: +44 (0) 20 7549 3300 • Fax: +44 (0) 20 7549 3349 • enquiries@ciria.org • www.ciria.org.uk
<p>EA Environment Agency Head Office Horizon House Deanery Road Bristol BS1 5AH</p>	<ul style="list-style-type: none"> • Telephone: 03708 506 506 • enquiries@environment-agency.gov.uk • www.environment-agency.gov.uk
<p>Highways England Bridge House, 1 Walnut Tree Close, Guildford GU1 4LZ</p>	<ul style="list-style-type: none"> • Telephone: 0300 123 5000 • info@highwaysengland.co.uk • www.highwaysengland.co.uk
<p>Office of Public Sector Information / The Stationery Office (Previously HMSO) TSO Orders/Post Cash Dept PO Box 29 Norwich NR3 1GN</p>	<ul style="list-style-type: none"> • Telephone: +44 (0)870 600 5522 • Fax: +44 (0)870 600 5533 • customer.services@tso.co.uk • www.tso.co.uk
<p>HR Wallingford (Formerly HRS) HR Wallingford Ltd, Howbery Park Wallingford Oxfordshire OX10 8BA</p>	<ul style="list-style-type: none"> • Telephone: +44 (0) 1491 835381 • Fax: +44 (0) 1491 832233 • info@hrwallingford.co.uk • www.hrwallingford.co.uk
<p>PJA Pipe Jacking Association 10 Greycoat Place London SW1P 1SB</p>	<ul style="list-style-type: none"> • Telephone: +44 (0)845 0705201 • Fax: +44 (0)845 0705202 • secretary@pipejacking.org • www.pipejacking.org

<p>TRL Transport Research Laboratory Crowthorne House Nine Mile Ride Wokingham Berkshire RG40 3GA</p>	<ul style="list-style-type: none"> • Telephone: +44 (0)1344 773131 • Fax: +44 (0)1344 770356 • enquiries@trl.co.uk • www.trl.co.uk
<p>UKSTT United Kingdom Society for Trenchless Technology 38 Holly Walk Leamington Spa Warwickshire CV32 4LY United Kingdom</p>	<ul style="list-style-type: none"> • Telephone: +44 (0)1926 330 935 • Fax: +44 (0)1926 330 935 • admin@ukstt.org.uk • www.ukstt.org.uk
<p>UK Water Industry Research Ltd BCSC 8th Floor 50 Broadway, London SW1H 0RG</p>	<ul style="list-style-type: none"> • Telephone: +44(0)20 7152 4537 • mail@ukwir.org.uk • www.ukwir.org/
<p>Water UK 3rd Floor 36 Broadway London SW1H 0BH</p>	<ul style="list-style-type: none"> • Telephone: +44 (0)20 7344 1844 • info@water.org.uk • www.water.org.uk
<p>WRc plc Frankland Road Blagrove Swindon Wiltshire SN5 8YF</p>	<ul style="list-style-type: none"> • Telephone: 01793 865000 • Fax: 01793 865001 • solutions@wrcplc.co.uk • www.wrcplc.co.uk

For further information contact:

British Precast Drainage Association

The Old Rectory, Main Street
 Glenfield, Leicester
 LE3 8DG
 Tel: 0116 232 5170
 Fax: 0116 232 5197
email@precastdrainage.co.uk
precastdrainage.co.uk



The information in this guide is to the best of our knowledge true and accurate, but all information provided is for guidance only and made without guarantee. Since the conditions of use are beyond their control, the British Precast Drainage Association disclaims any liability for loss or damage resulting from the use of this guide. Furthermore, no liability is accepted if use of any products in accordance with this data or these suggestions infringes any patent. The British Precast Drainage Association reserves the right to change product specifications and references without notice.

